

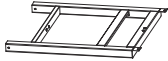

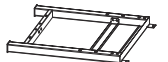









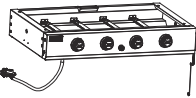

No.	#	QYT / CANT. / QTÉ	Description / Descripción / Description	Image / Imagen / Image
1	GD19J20JGZL01H	1	Leg assembly (L) Conjunto de pata (I) Assemblage du pied (G)	
2	GD19J20JGZR01H	1	Leg assembly (R) Conjunto de pata (D) Assemblage du pied (D)	
3	GD19JHL03H4B	3	Cart beam Puntal del carro Poutre de chariot	
4	07-QPG-01-BK	1	LP cylinder hook Gancho para bombona de gas Crochet de bouteille de GPL	
5	07-QPG-02-BK	1	LP cylinder base Base de la bombona de gas Base de bouteille de GPL	
6	05-WXL-06	2	Caster Rueda Roulette	
7	06-XZL-1-77-DY	1	Wheel axle Eje de las ruedas Axe de roue	
8	05-SLL-27-BK	2	Wheel Rueda Roue	
9		1	Main body Cuerpo principal Corps principal	
10	GD19JLJJQP01L	1	Main body cart joint (L) Junta del carro del cuerpo principal (I) Joint de chariot du corps principal (G)	
11	GD19JLJJQP01R	1	Main body cart joint (R) Junta del carro del cuerpo principal (D) Joint de chariot du corps principal (D)	
12	GD19T2GDZJ01	2	Side table bracket Tirante de mesa lateral Support de table d'appoint	
13	GD19T2GDZJ02	2	Side table bracket Tirante de mesa lateral Support de table d'appoint	
14	GD19T7CTL02	1	Side table (L) Mesa lateral (I) Table d'appoint (G)	
15	GD19T7HDZJ01	2	Side table folding bracket Soporte plegable de la mesa lateral Support pliable de la mesa lateral	
16	GD19T7HDZJ02	2	Side table folding bracket Soporte plegable de la mesa lateral Support pliable de la mesa lateral	
17	GD19T7CTR02	1	Side table (R) Mesa lateral (D) Table d'appoint (D)	
18	GD19P601H4B-HS	1	Cooking griddle Plancha superior Plaque de cuisson	

No.	#	QYT / CANT. / QTÉ	Description / Descripción / Description	Image / Imagen / Image
19	GD19LYB01H	1	Grease cup Depósito de recogida de grasa Bac à graisse	

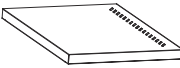
Key / Clave / Réf.	Description / Descripción / Description	QTY / CANT. / QTÉ	Image / Imagen / Image
A	M6x12	48	
B	Split pin Pasador partido Goupille fendue	1	
C	M6	8	
D	M6x30	4	
E	M6	4	

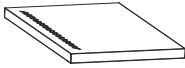
TOOLS REQUIRED / HERRAMIENTAS REQUERIDAS / OUTILS REQUIS		
Description / Descripción / Description		Image / Imagen / Image
Phillips screwdriver Destornillador phillips Tournevis phillips	Wrench Llave Clé	

Before beginning assembly, make sure all parts are present. If any parts are missing or damaged, do not attempt to assemble the products. Contact customer service for replacement parts via telephone or email.

- Tools needed (not included): Phillips screwdriver and wrench
- Approximate assembly time: 40 minutes
- Note: 1. The right and left sides of the griddle are designed as if you are facing the front of the griddle.
2. Model shown for illustration purpose only, specific please in kind prevail.

Antes de comenzar el montaje, asegúrese de que todas las piezas estén presentes. Si falta alguna pieza o está dañada, no intente ensamblar los productos. Póngase en contacto con el servicio de atención al cliente para obtener piezas de repuesto por teléfono o correo electrónico.

- Herramienta necesaria (no incluido): Destornillador phillips y llave
- Tiempo aproximado de ensamblaje: 40 minutos
- Nota: 1. Los lados derecho e izquierdo de la plancha están diseñados como si estuvieras frente a la parte delantera de la plancha.
2. El modelo que se muestra es sólo para fines ilustrativos, prevalecen los específicos en especie.

Avant de commencer l'assemblage, assurez-vous que toutes les pièces sont présentes. Si des pièces sont manquantes ou endommagées, n'essayez pas d'assembler les produits. Contactez le service de clientèle pour les pièces de rechange par téléphone ou par e-mail.

- Outils nécessaires (non inclus): Tournevis phillips et clé
- Temps nécessaire pour l'assemblage: 40 minutes
- Remarque: 1. Les côtés droit et gauche du plaque de cuisson sont concus comme si vous faisiez face à l'avant du plaque de cuisson.
2. Le modèle est présenté à des fins d'illustration uniquement, spécifiques en nature prévalent.

1 A  ⊕ ×8

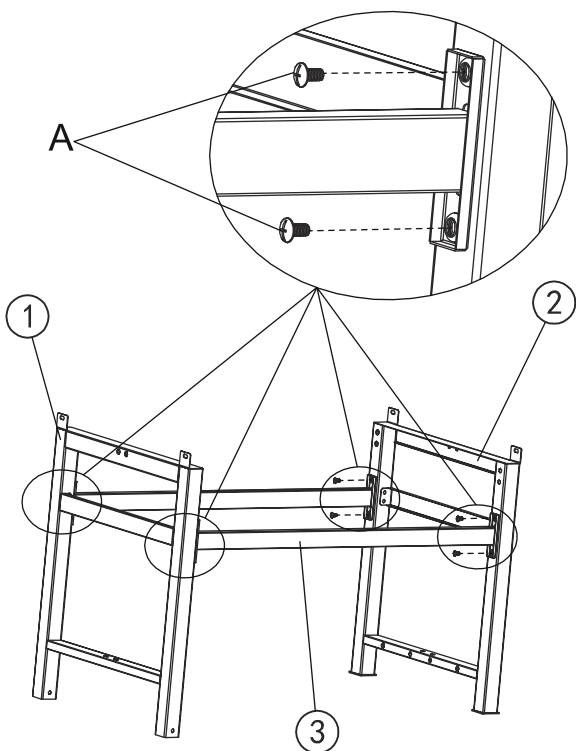

2 A  ⊕ ×4

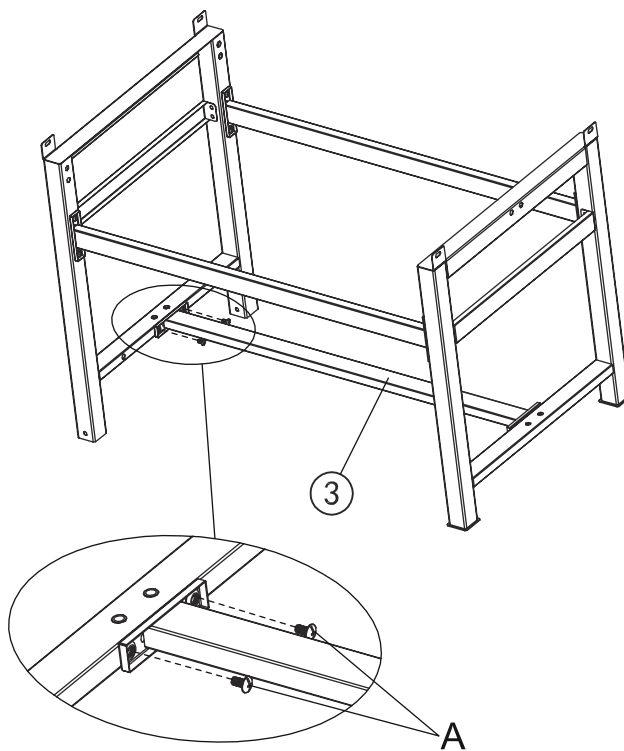

3 A  ⊕ ×4

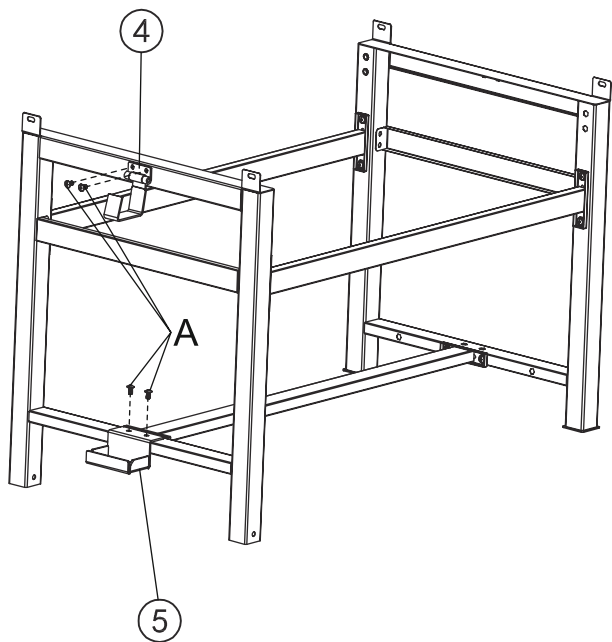

4

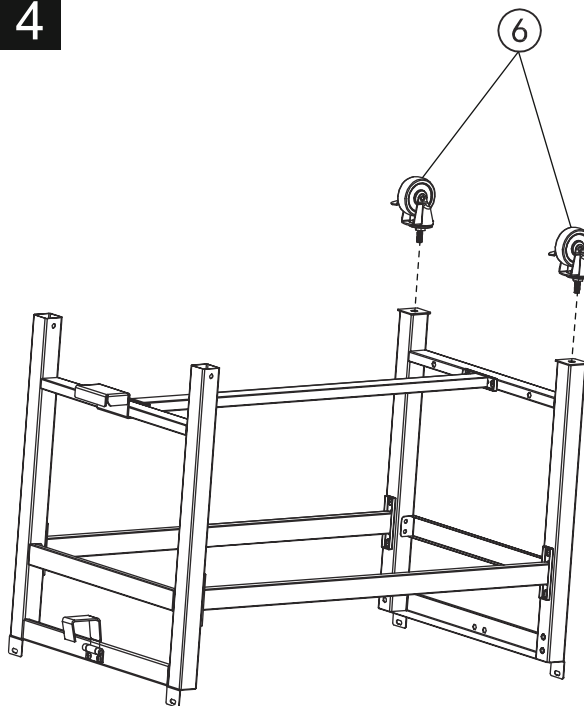

5 B  x1

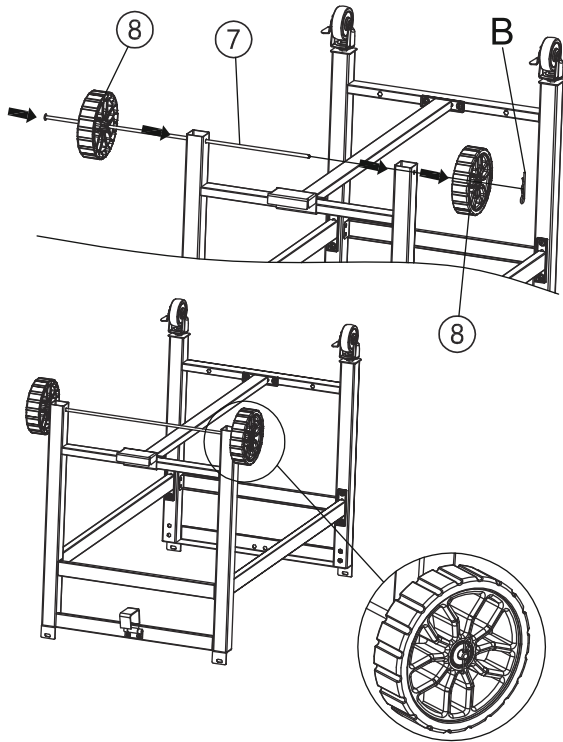

6

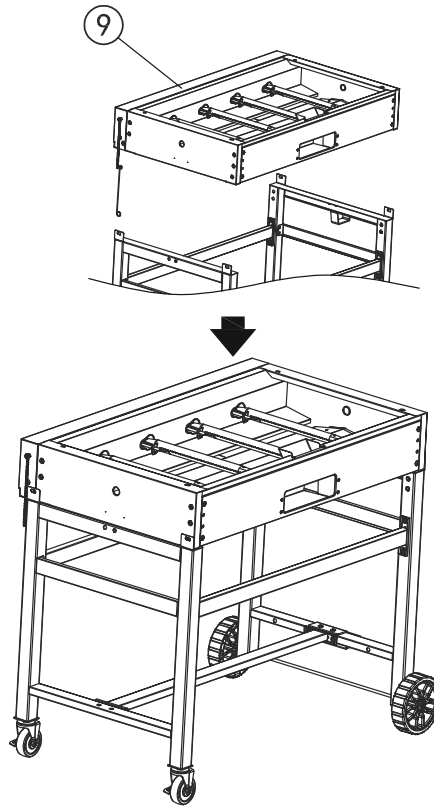

- Make sure the main body's backside is flush with the rear of leg assembly.
- Asegúrese de alinear detrás de la parte principal con la parte trasera del montaje de las patas.
- Assurez-vous que l'arrière du corps principal est aligné avec l'arrière de l'assemblage des pieds.

7 A  x12

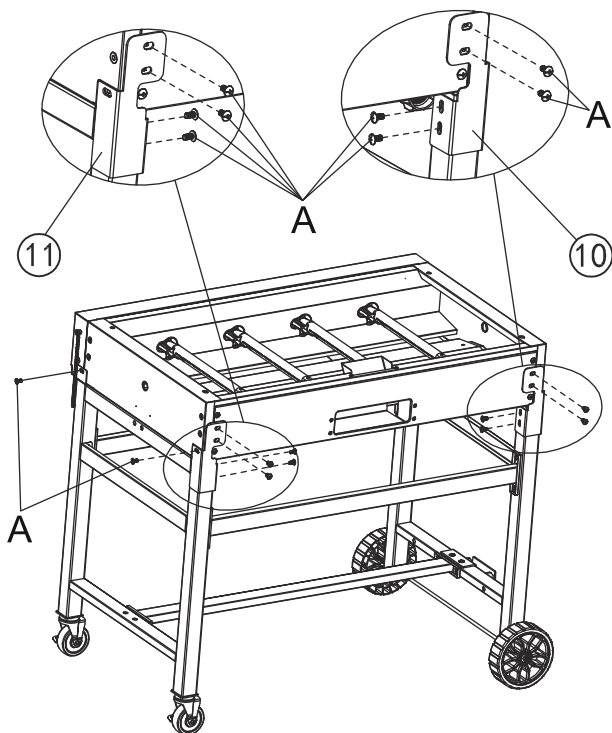

8 A  x8

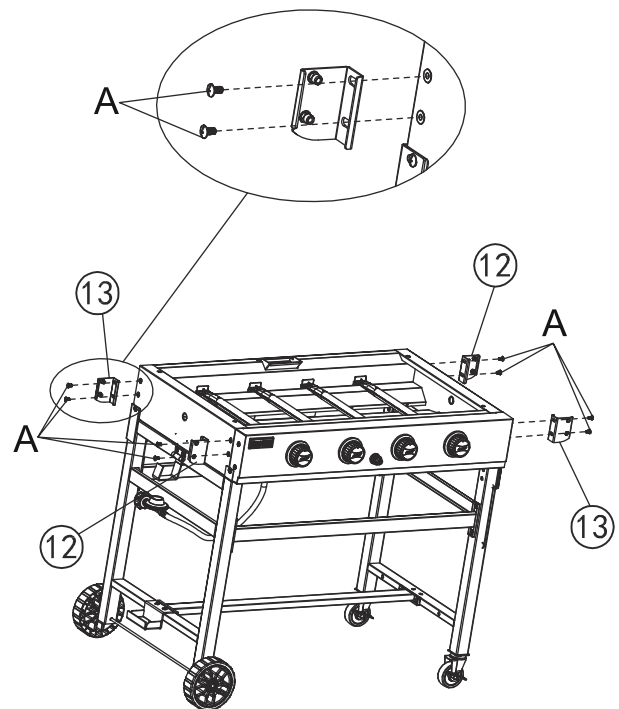

9 A  ×6

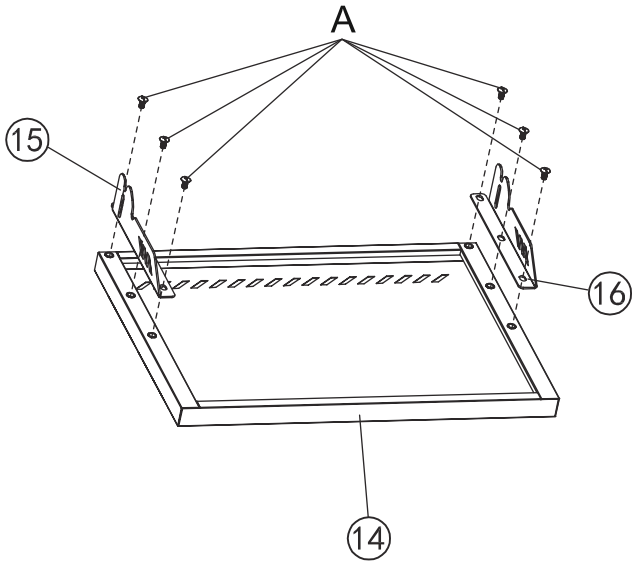

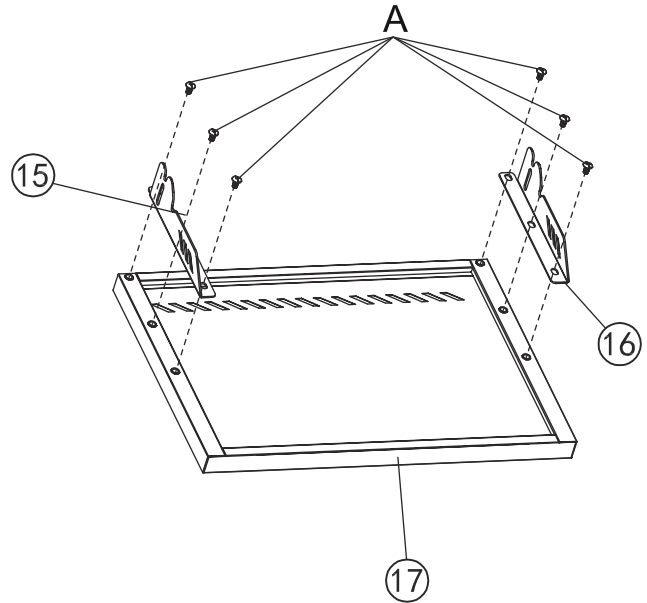

10 A  ×6

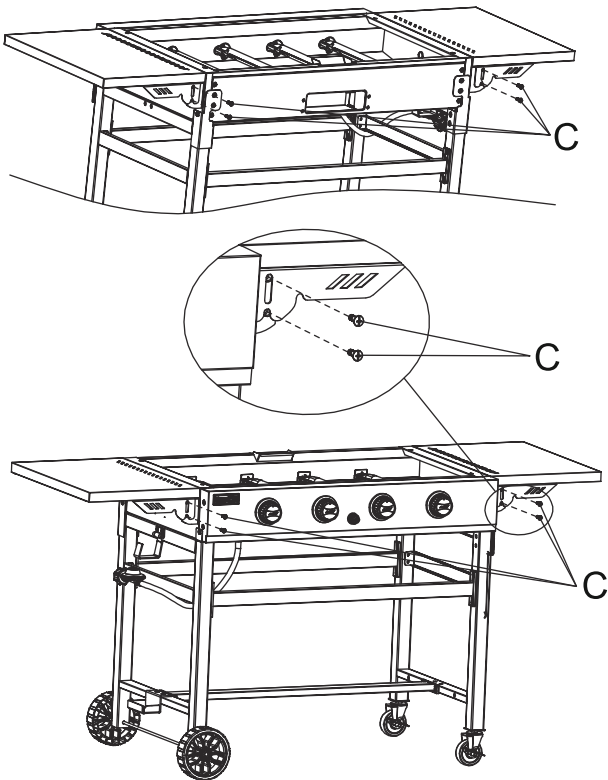

11 C  ×8



12 E  ×4 D  ×4

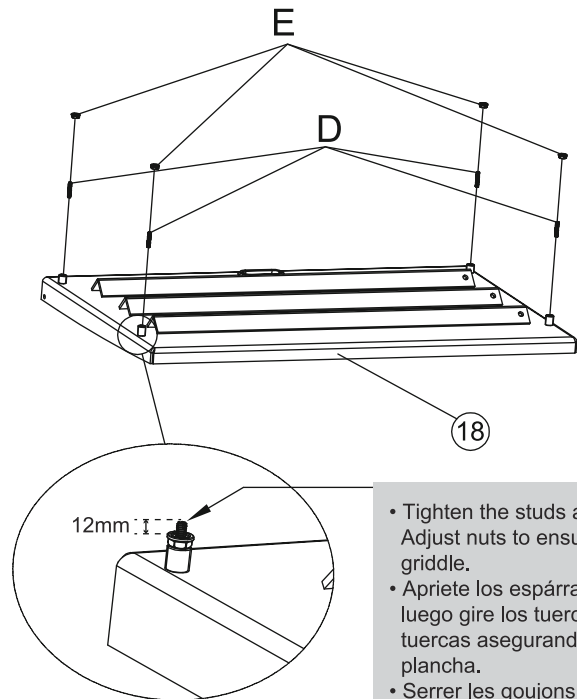

- Tighten the studs and then twist nuts. Adjust nuts to ensure the flatness of griddle.
- Apriete los espárragos roscados y luego gire los tuercas. Ajustar las tuercas asegurando la planitud de la plancha.
- Serrer les goujons, puis visser les écrous. Ajustez les écrous pour assurer la planéité de la plaque.

13

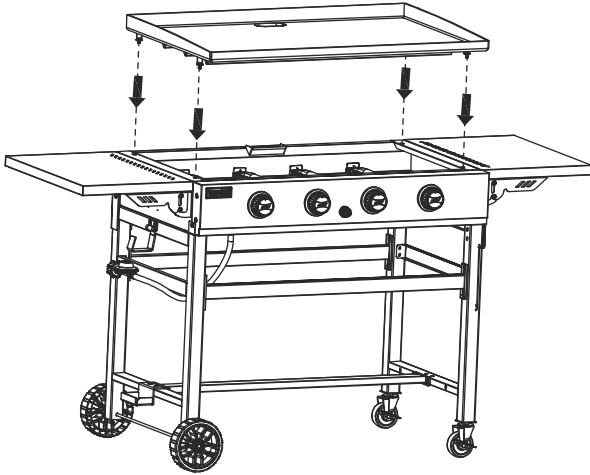

14

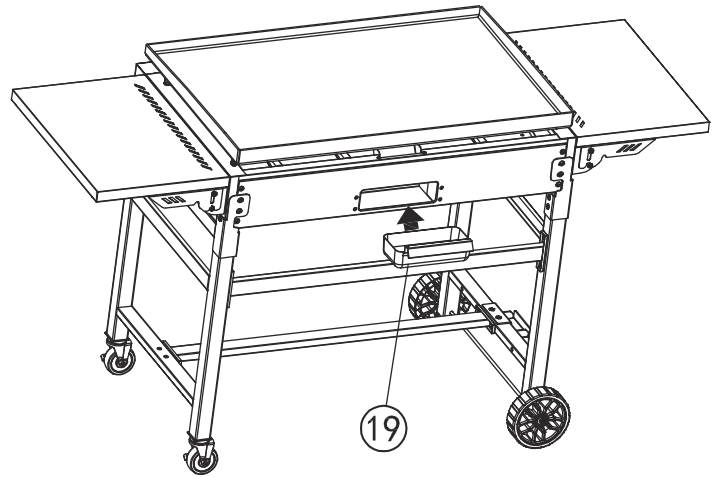

15

- AA battery not included.
- Pila AA no incluida.
- Pile AA non incluse.

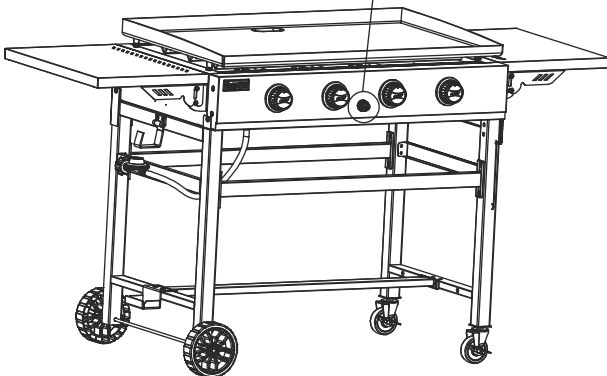
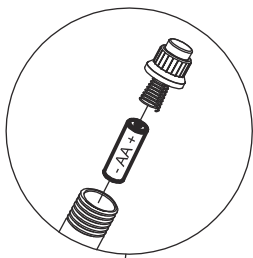

16

- Not included.
- No incluida.
- Non incluse.

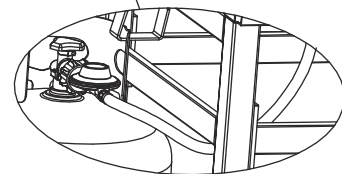
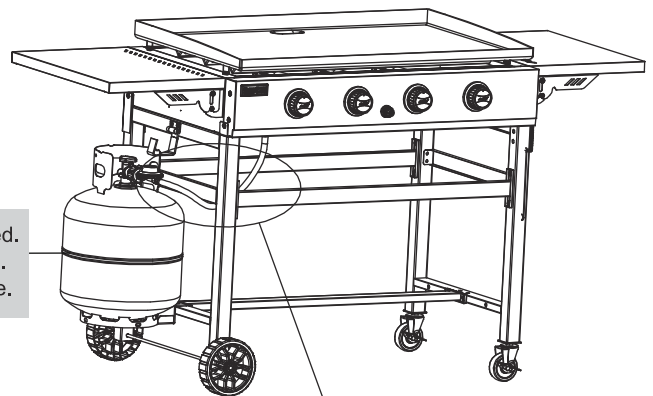

- Make sure the propane hose passes under the cart beam.
- Asegúrese de que la manguera de propano pase por debajo de la viga del carrito.
- Assurez-vous que le tuyau de propane passe sous la poutre du chariot.

**Thank You
For Choosing Us.**

**Any Problem!
We Can Help!**

**Customer
Service**

1-800-618-6798

Monday to Friday (8:30 am - 5:00 pm EST)

service@royalgourmetusa.com