

1.4k60/1.4k84



1,400 lbs (635 kg) Capacity - Models 1.4k60 & 1.4k84

Manual & Electric drive versions

- ASSEMBLY
- INSTALLATION
- REPLACEMENT PARTS

**READ complete manual CAREFULLY
BEFORE attempting assembly or operation**

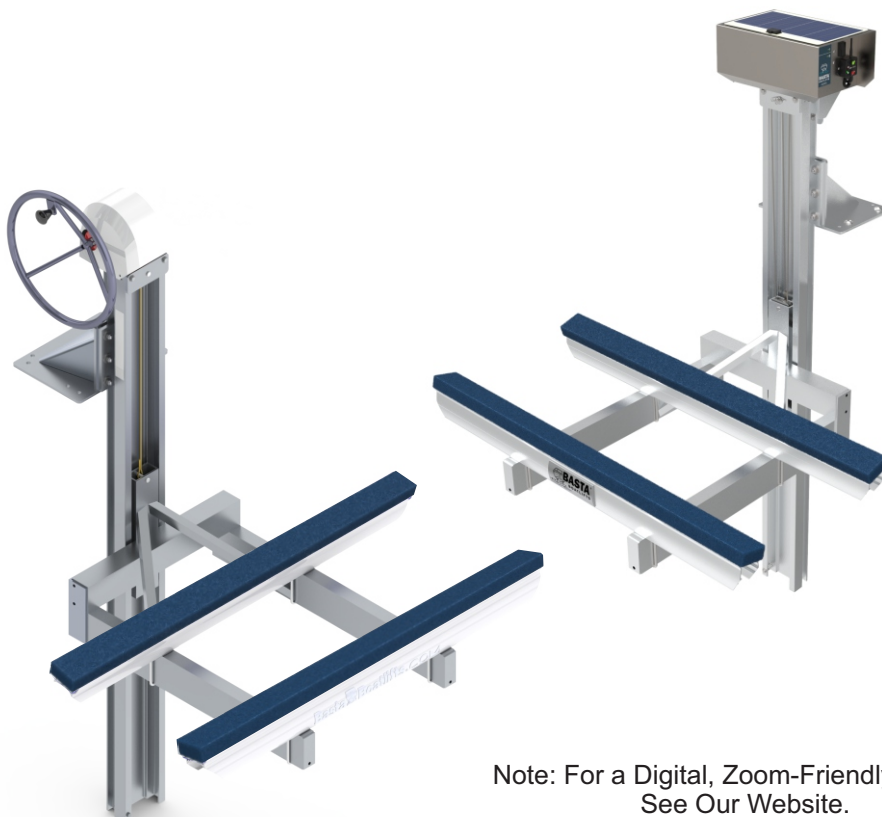

Note: For a Digital, Zoom-Friendly Version;
See Our Website.

INDEX

Warning.....Page 2, 3
Parts List and Dimensions.....Pages 4 - 9, 25
Install Tips / Assembly Instructions.....Pages 10 - 29
First Use / Adjustments.....Page 30
Warranty.....Page 31-32

DANGER

- Do not exceed the maximum weight capacity specified for the lift structure or 12V Electric Drive Upgrade Kit. Abide by whichever capacity is lower.
Maximum weight capacity of lift model can be located on the capacity sticker of the lift tower.
Maximum capacity of 12V Electric Drive Upgrade Kit is on the hoist cover.
Improper use or failure to follow this instruction can cause property damage, serious injury, or death.
- Never use for lifting humans or animals.
Improper use or failure to follow this instruction can cause property damage, serious injury, or death.
The lift should only be used for lifting boats & watercraft.
- Always avoid being under, and maintain adequate clearance from, the lift.
Failure to follow this instruction can cause serious injury or death.
- Keep fingers and other foreign objects clear of the hoist and cable while it is being operated.
Serious injury may result.
- Always use AGM batteries and follow battery manufacturer's warnings and instructions.
Improper use, or use of other batteries, have the potential to produce flammable hydrogen gas

WARNING

- Visually inspect all parts and assemblies for damage or defects prior to assembling lift.
- Do not play on or near the lift.
- Do not service the unit with the watercraft on the lift.
- Do not install the lift alone.
- Install the lift only on a structurally sound and level dock.
- Verify the lift tower is vertical both side to side and front to back before use.
- Service your lift regularly.

CAUTION

- The lift should only be used for lifting boats & watercraft.
- Passengers should stand clear of the lift when the lift is in operation.
- Use a mooring line for additional security.

MAXIMUM CAPACITY
1,400 LBS (635 kgs)
⚠ DANGER
Do not exceed the maximum weight capacity specified for the lift.

MAXIMUM BEAM
55" (140 cm)
⚠ WARNING
Do not exceed the maximum beam specified for the lift.

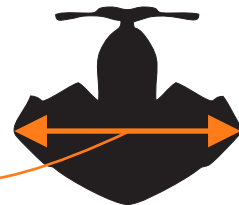



Before Using:

Read this manual completely!



INSPECT the lift monthly

for frayed cable, loose fasteners and corrosion



Do not use to lift humans

Exceeding lift capacity may result in structural failure, injury or death

! DANGER

Avoid all moving parts to prevent death or serious injury



STAY CLEAR!

INSTALLATION

Please inspect your dock *thoroughly* before installing the lift and make sure that all wood is in good condition and securely attached. If necessary, cut a notch in any cosmetic dock fascia board to allow the lift mount to be bolted through a heavier structural member.

Only stainless steel or galvanized hardware should be used to install the lift. ***Due to the highly customized nature of each installation, installation hardware is not supplied with the lift kit.***

CAUTION should be exercised to ensure your safety at all times.

For safety and proper operation, the lift tower should be plumb (vertical) side-to-side and front to back so the carriage forks are horizontal.

The lower end of the tower *must* be securely attached to the dock.

We recommend that you hire a professional to install your lift.

After the lift is assembled and installed, all fasteners should be checked for proper tightness and reinspected periodically.

In the following pages various symbols are used:

AA

indicates a major part described in the parts list on pages 4 - 9.

11 or **1&2**

indicate hardware items shown above and described in the parts list on pages 4 - 9.

For a full list of patents, go to:

bastaboatlifts.com/patents

UNIVERSAL PARTS

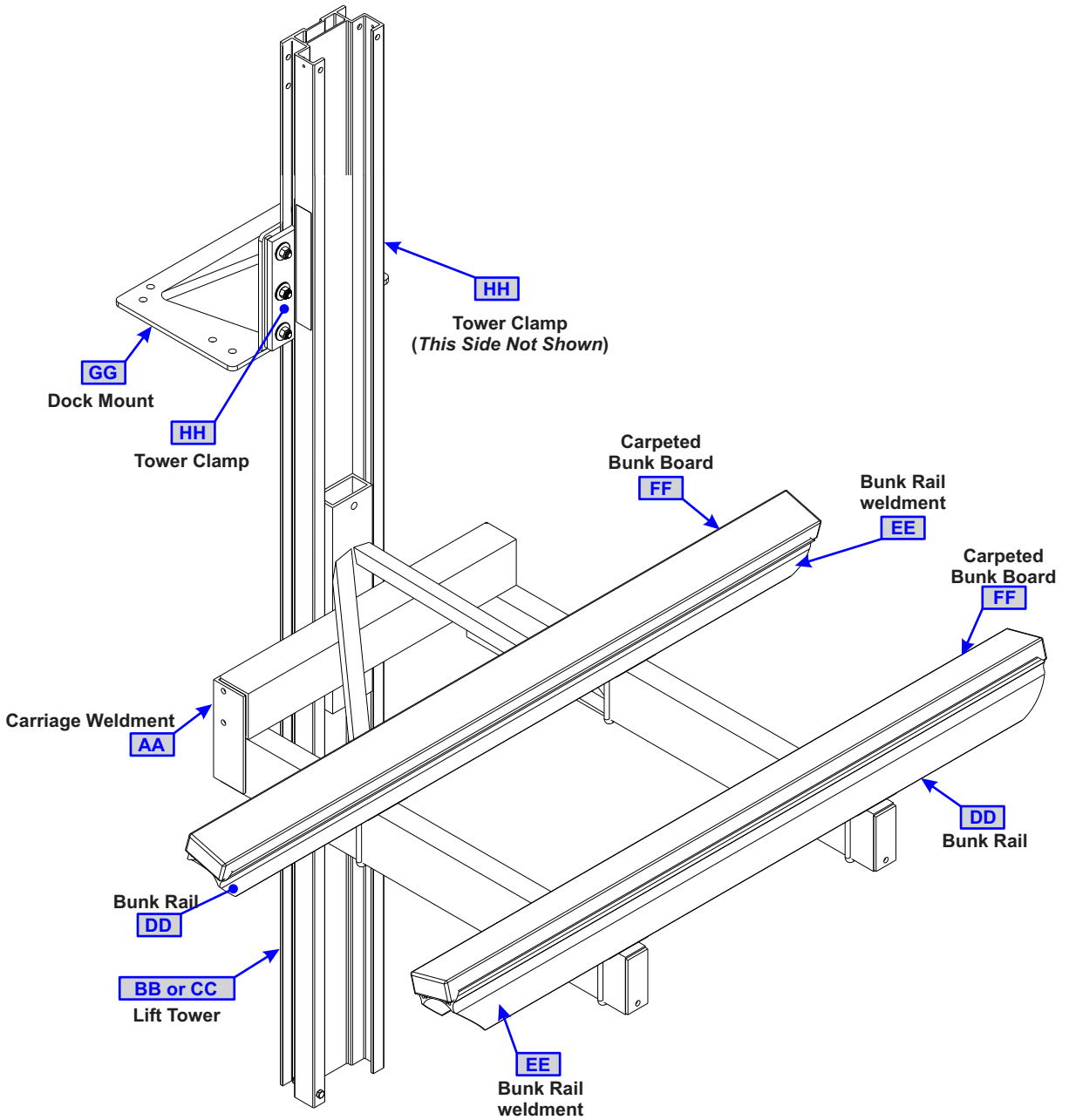

UNIVERSAL PARTS LIST

ITEM	PART NO.	DESCRIPTION	QTY.
AA	W125-0004	Carriage Weldment	1
BB	W125-0001	Tower Weldment (1.4k60)	1
CC	W125-0006	Tower Weldment (1.4k84)	1
DD	A427-0016	Bunk Rail Assembly (EE + FF)	2
EE	W114-0010	Bunk Rail Weldment (part of LL)	N/A
FF	W410-0068	Blue Bunk Board (part of LL)	N/A
GG	W125-0002	Dock Mount Weldment	1
HH	W125-0003	Tower Clamp	2

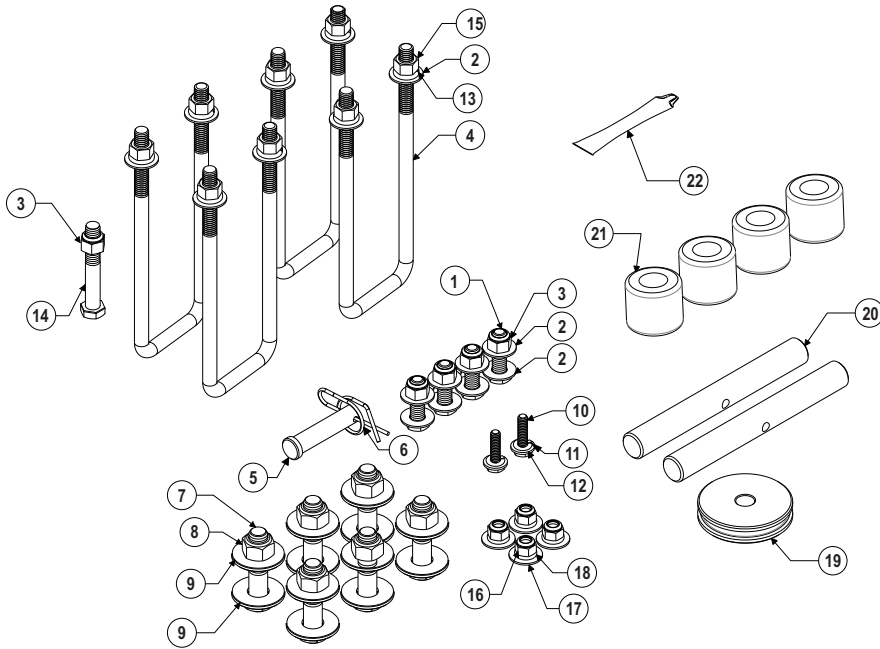

ITEM	PART NO.	DESCRIPTION	QTY.
1	S103-0506	bolt, hex head 3/8-16 x 1.25 SS	4
2	S313-0008	washer, flat 3/8 SS	22
3	S362-0008	nut, 3/8-16 nylock SS	5
4	S170-6507	U-bolt, square 3/8 x 2 x 6 SS	4
5	S501-0507	clevis pin, 1/2 x 2-1/2 SS	1
6	S522-0801	ring type cotter pin, SS	1
7	S103-0709	bolt, hex head 1/2-13 x 2 SS	6
8	S362-0010	nut, 1/2-13 nylock SS	6
9	S313-0010	washer, flat 1/2 SS	12
10	S103-0306	bolt, hex head 1/4 x 1.25 SS	2
11	S322-0006	washer, lock 1/4 SS	2

ITEM	PART NO.	DESCRIPTION	QTY.
12	S313-0006	washer, flat 1/4 SS	2
13	S322-0008	washer, lock 3/8 SS	8
14	S103-0511	bolt, hex head 3/8-16 x 2.5 SS	1
15	S342-0008	nut 3/8-16 SS	8
16	S362-0007	nut, 5/16-18 SS (part of LL)	4
17	S313-0007	washer, flat 5/16 SS (part of LL)	4
18	S322-0007	washer, lock 5/16 SS (part of LL)	4
19	M413-1001	sheave	1
20	M532-6601	axle	2
21	M502-6002	roller	4
22	Y356-0003	anti-seize compound	1

MANUAL PARTS

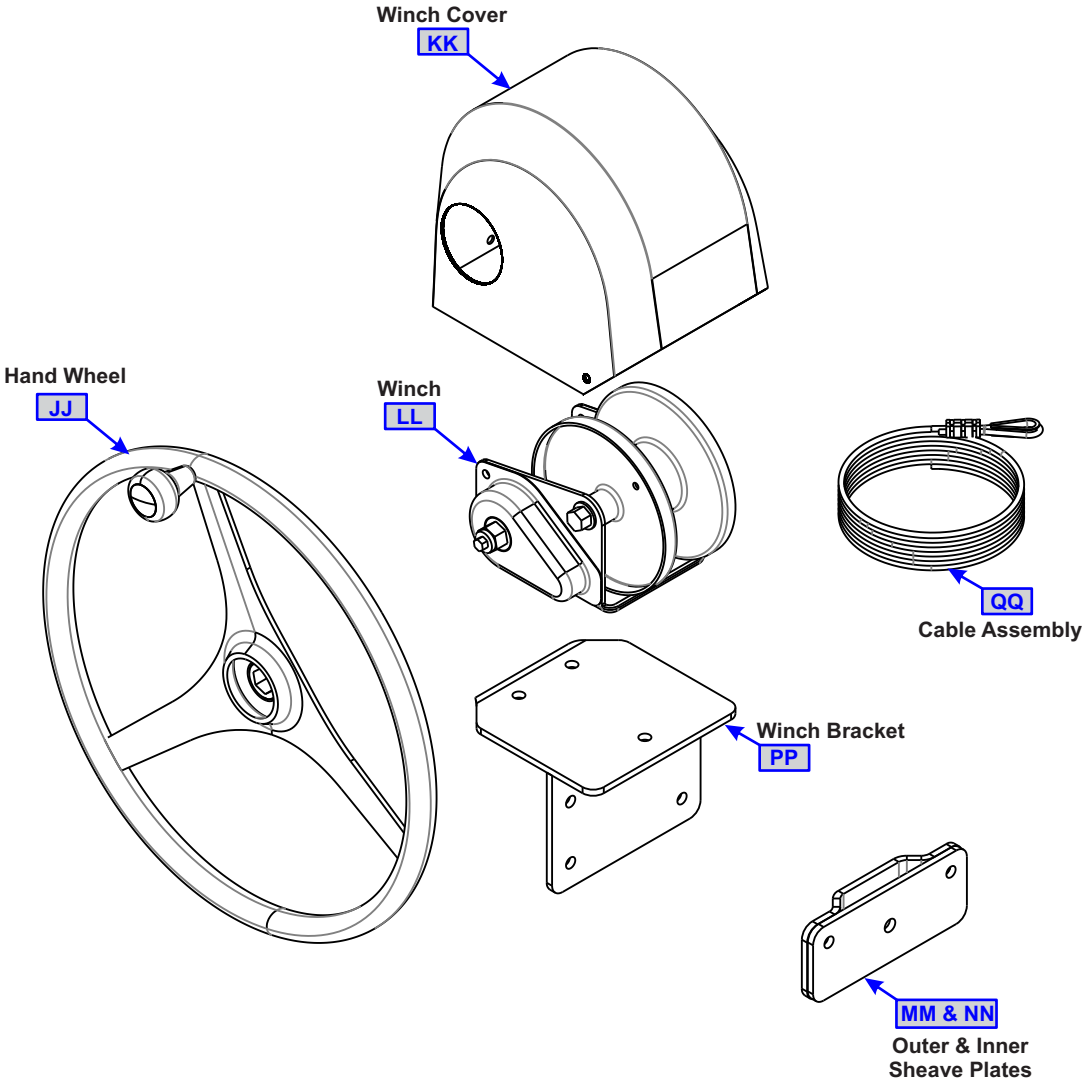

MANUAL DRIVE PARTS LIST

ITEM	PART NO.	DESCRIPTION	QTY.
JJ	A412-0003	Hand Wheel	1
KK	C250-0002	Winch cover	1
LL	M710-3001	Winch	1
MM	K205-0014	Sheave Plate, Outer	1
NN	K205-0013	Sheave Plate, Inner	1
PP	W125-0005	Winch Bracket Weldment	1
QQ	M330-0001	cable assembly	1

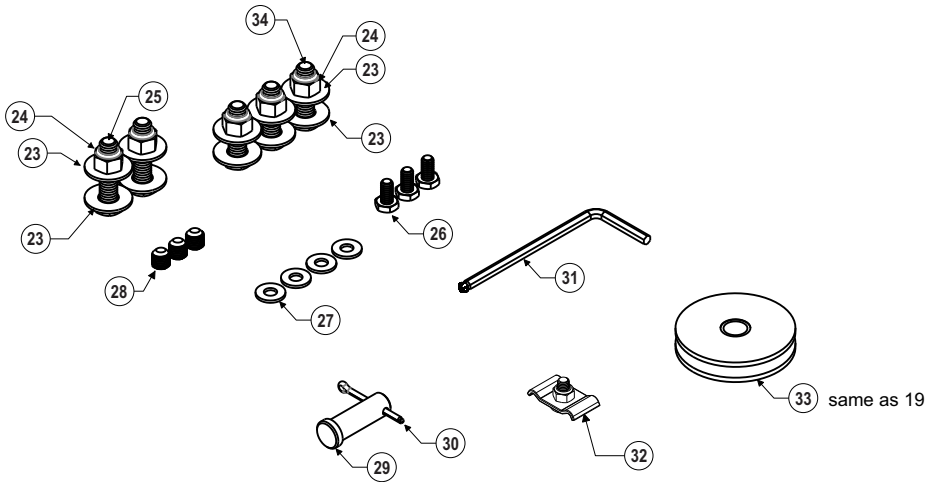

ITEM	PART NO.	DESCRIPTION	QTY.
23	S313-0008	washer, flat 3/8 SS	8
24	S362-0008	nut, 3/8-16 nylock SS	10
25	S103-0507	bolt, hex head 3/8 x 1.5 SS	2
26	S103-0301	bolt, hex head 1/4 x 0.50 SS	3
27	S313-0006	washer, flat 1/4 SS	4
28	S160-6537	3/8"-24 x 3/8" cut point set screw	3
29	S501-0503	clevis pin, 1/2 x 1-1/2 SS	1
30	S520-1504	cotter pin, 1/8 x 1-1/2 SS	1
31	Q501-2001	Allen wrench 3/16"	1
32	M750-0002	winch cable clamp assembly (part of LL)	1
33	M413-1001	sheave	1
34	S103-0506	bolt, hex head 3/8-16 x 1.25 SS	3

12V ELECTRIC DRIVE

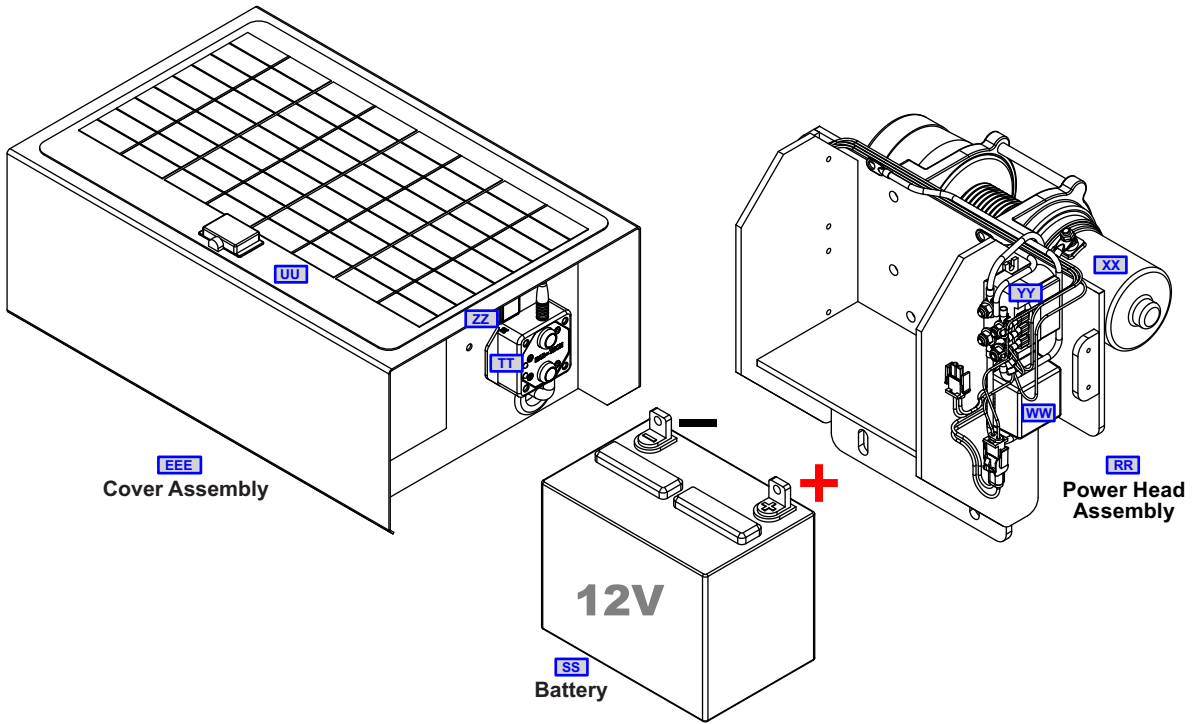

12V DRIVE PARTS LIST

ITEM	PART NO.	DESCRIPTION	QTY.
RR	A405-0022	Power Head Assembly	1
SS	R285-1005	Battery	1
TT	R810-0013	Remote Control Assembly	1
UU	R281-0004	Solar Panel Assembly	1
VV	R330-1020	Fuse, 5A	1
WW	R283-0002	Solar Panel Controller	1
XX	M730-0003	Hoist	1
YY	R321-0002	Hoist Contactor	1
ZZ	W310-0001	Power Switch	1
AAA	M330-0004	Cable Assembly, 3/16"	1
BBB	K205-4017	Upper Magnet Switch Plate	1
CCC	W125-0011	Lower Magnet Switch Plate	1
DDD	M651-0001	Tensioner Block	1
EEE	A405-0021	Cover Assembly	1

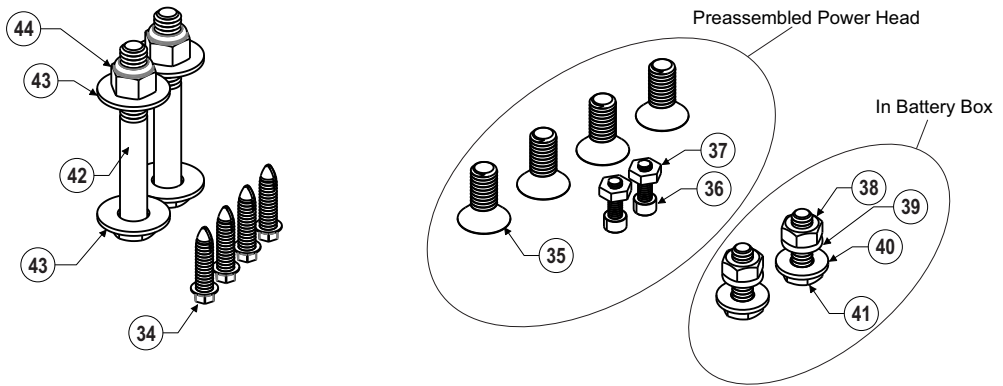

ITEM	PART NO.	DESCRIPTION	QTY.
34	S127-1803	Screw, thread cutting #14 x 1.0 SS	4
35	S218-0507	Screw, socket flat M8 x 1.25 SS	4
36	S113-0101	Machine bolt, 8-32 x 0.5 SS	2
37	S342-0003	Nut, #8 SS	2
38	S342-0006	Nut, 1/4-20 SS	2
39	S322-0006	Washer, lock 1/4 SS	2
40	S313-0006	Washer, flat SS	2
41	S103-0303	bolt, hex head 1/4-20 x 0.75 SS	2
42	S103-0512	Bolt, hex head 3/8-16 x 2.75 SS	2
43	S313-0008	Washer, flat 3/8 SS	4
44	S362-0008	Nut, 3/8-16 Nylock SS	2

OPTIONAL: SHORTENING LIFT HEIGHT/TRAVEL

In certain scenarios the full height/travel of the lift will not be needed or desired.

In these cases it is possible to cut down the length of the tower weldment to the desired height/travel.

Note: this alteration requires sawing/drilling aluminum.

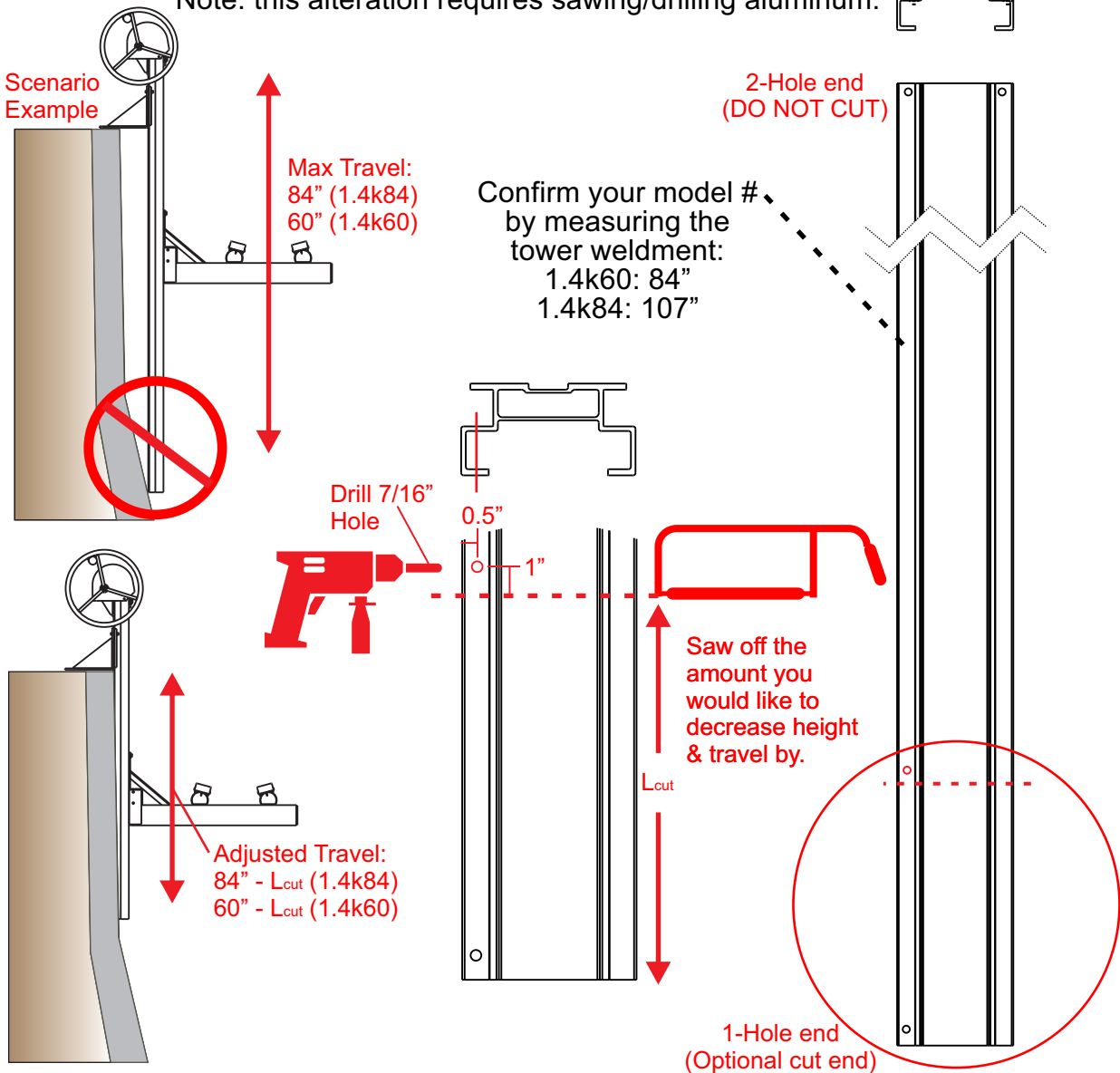

INSTALLATION TIPS

NOTE: Do to the variation in docks styles & types of installations
There is no one-size-fits all method of installation.
Below is a set of tips and scenarios that are meant to act
as a framework to guide the user in their decision
of how best to mount their lift.

Dock Mount

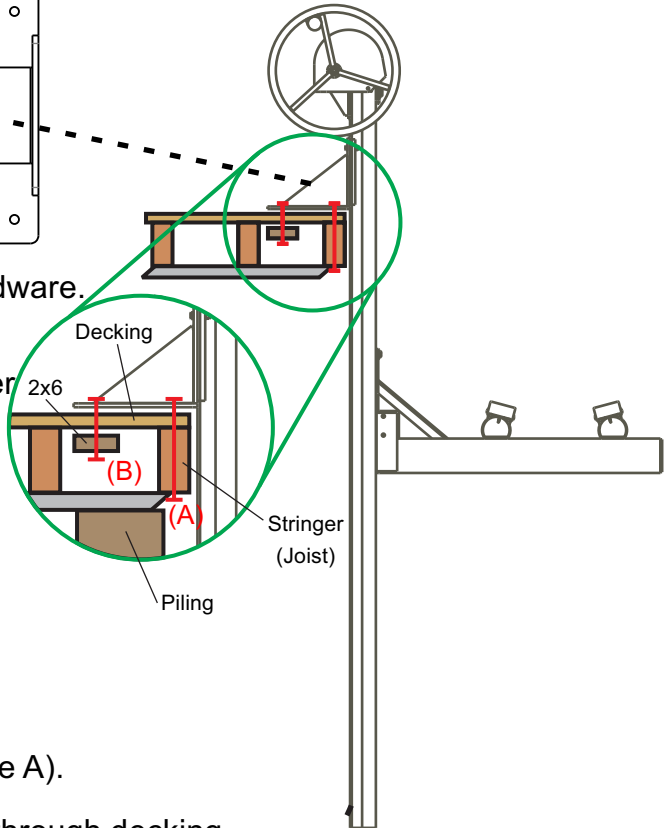
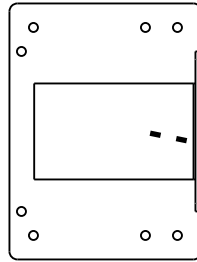

Use 1/2" stainless or galvanized hardware.

The dock mount weldment requires 4 mounting points, one in each corner (multiple holes given as options).

Through bolt style hardware is recommended over lag bolting. The back dock mount holes must be through bolted.

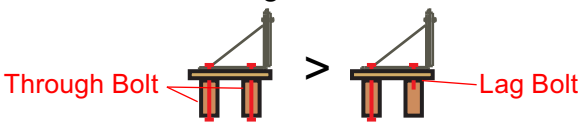

Where possible, through bolt all the way through a dock stringer/joist (See A).

In situations where you must mount through decking, use a 2x6 (at least 3 ft long) spanning both bolts beneath the decking to spread out the load (See B)

Tower Bottom

Tower bottom **MUST** be mounted to the dock, dock support structure or to the ground.

EXAMPLE MOUNTING SCENARIOS

NOTE: These sample scenarios are meant to act as a guiding frame work, not specific instructions for the owner's unique mounting situation.

In-Line With a Single Piling

Tips:

Mount the dock mount according to the best practices laid out on page 11.

Mounting directly to a piling is a good option, though a spacer may be required.

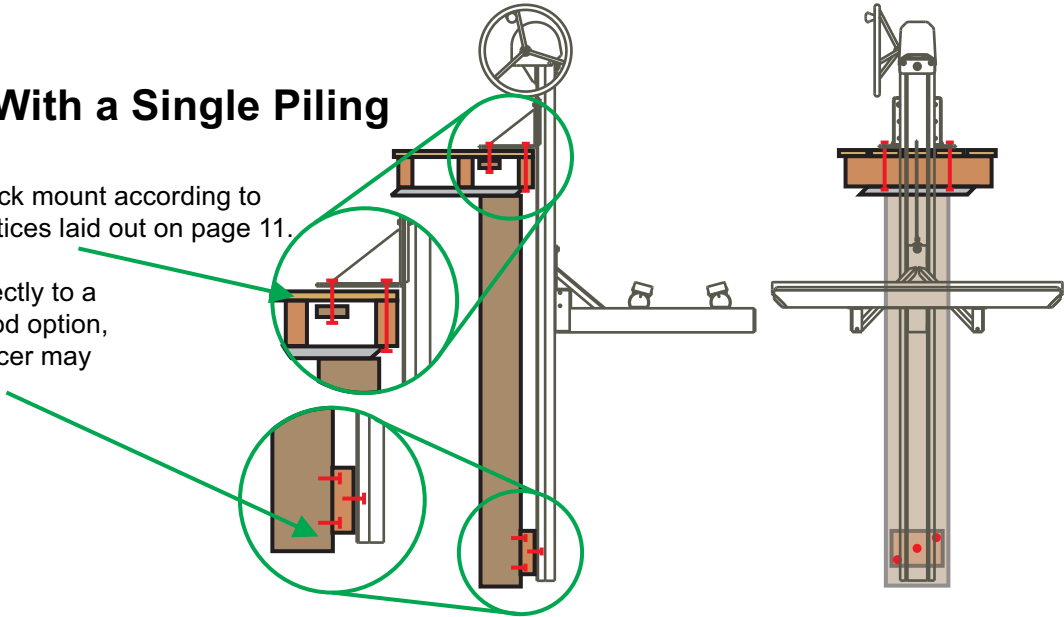

In-between Two Pilings

Tips:

Mount the dock mount according to the best practices laid out on page 11.

If the tower does not line up with a piling, you can run a stringer between two pilings and mount the tower to it.

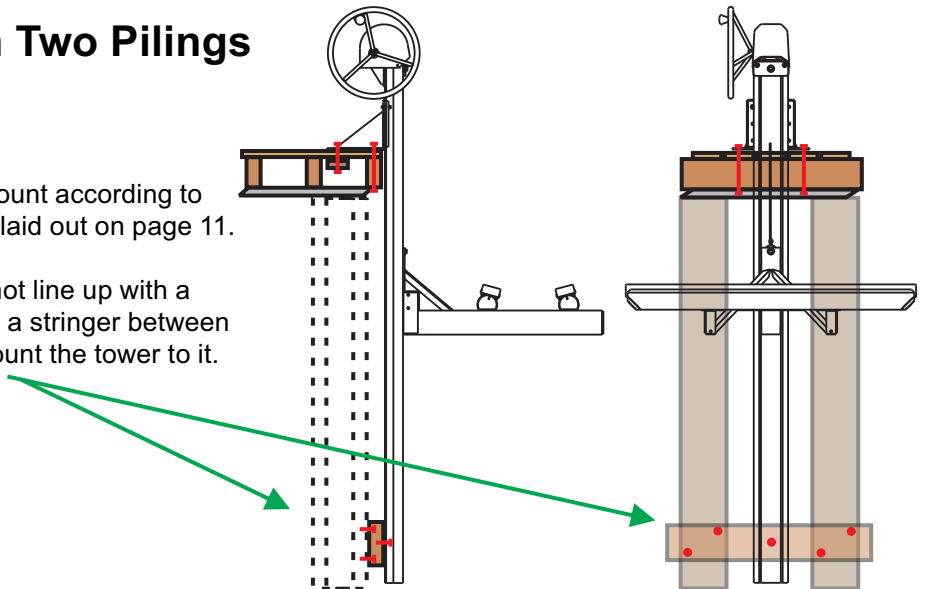

Dock without Pilings

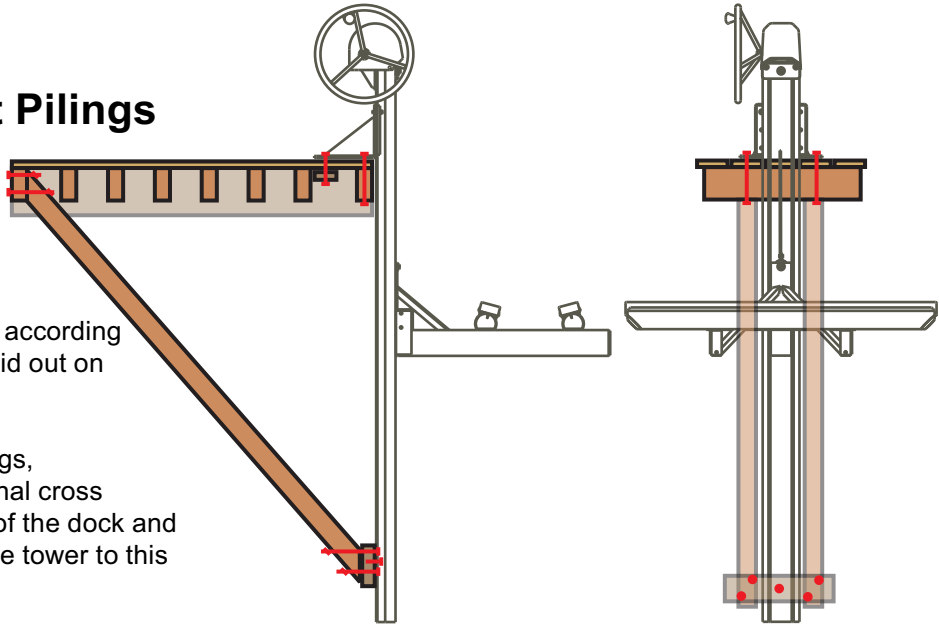

Tips:

Mount the dock mount according to the best practices laid out on page 11.

For docks without pilings, You can employ diagonal cross bracing to the far end of the dock and mount the bottom of the tower to this bracing structure.

Bulkhead Mounting

Tips:

Spacers can be employed on either side of the bulkhead to achieve the required four points of attachment to the dock mount.

The bottom of the tower can be attached directly to the bulkhead or via spacer, depending on clearance.

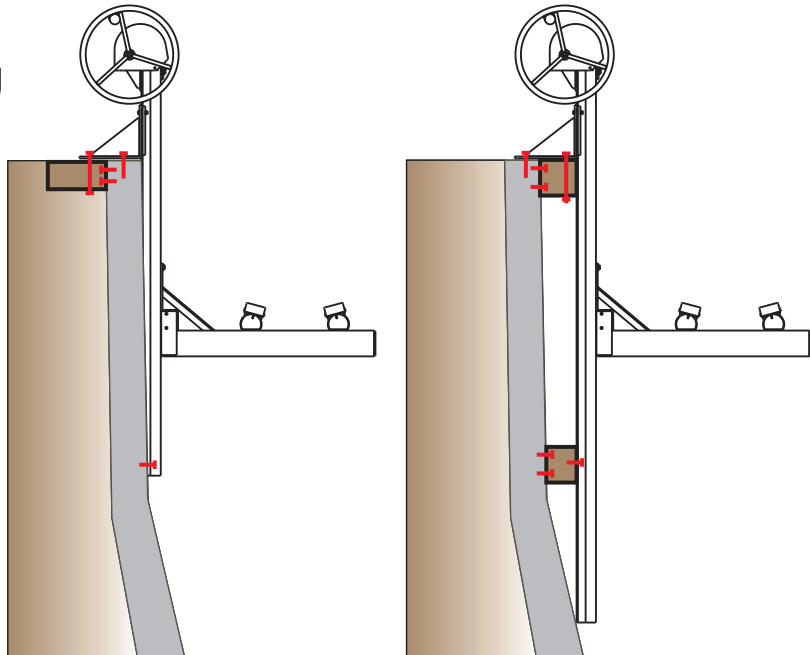

ASSEMBLY INSTRUCTIONS

NOTE: use a small amount of anti-seize on bolt threads

Tower Assembly

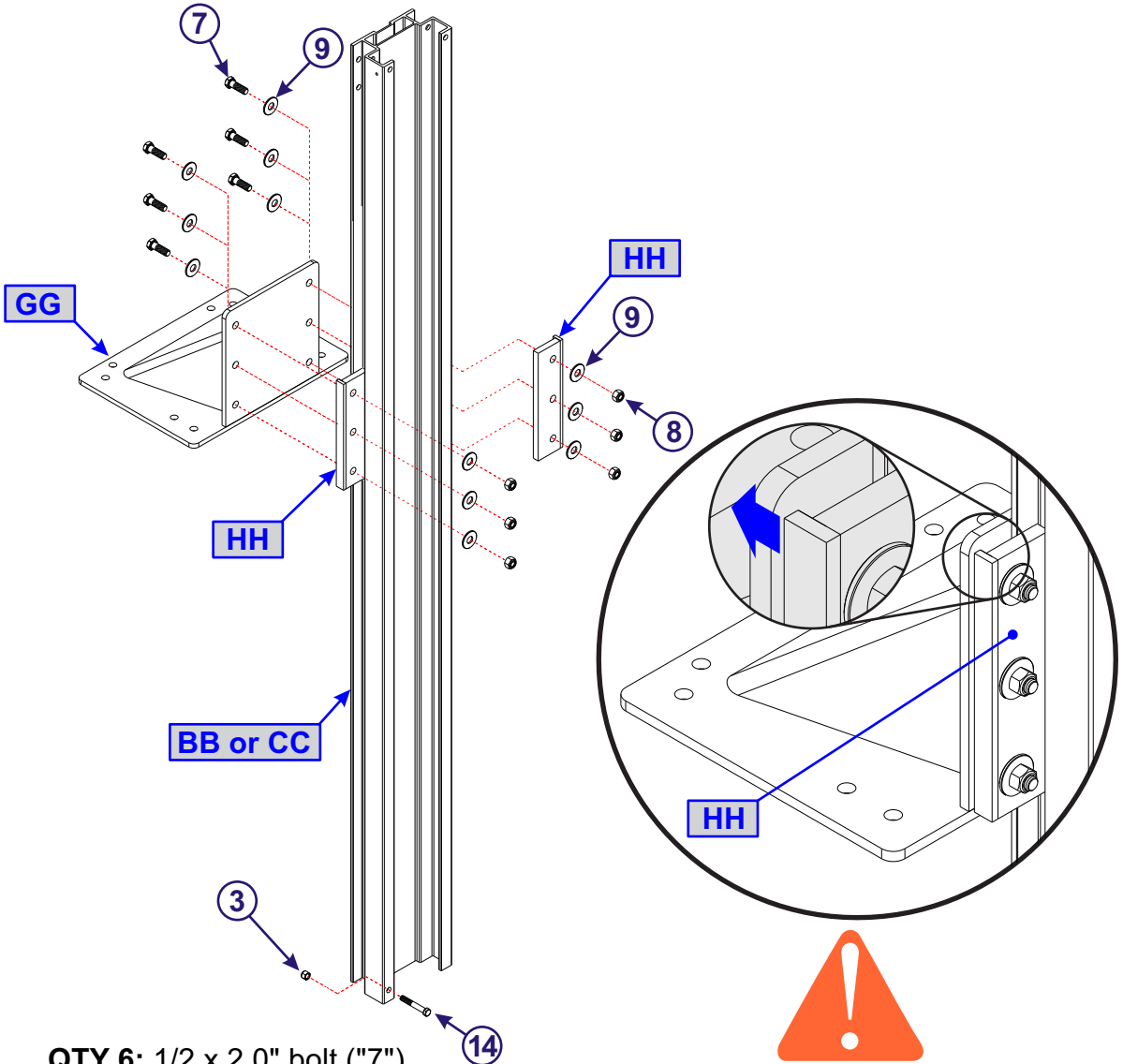

- QTY 6: 1/2 x 2.0" bolt ("7")
- QTY 6: 1/2 nylock nut ("8")
- QTY 12: 1/2 flat washer ("9")
- QTY 1: 3/8 x 2.5" bolt ("14")
- QTY 1: 3/8 nylock nut ("3")



Tower clamps **HH** are "L" shaped & **MUST** face in direction shown above

ASSEMBLY INSTRUCTIONS

NOTE: use a small amount of anti-seize on bolt threads

Roller Installation

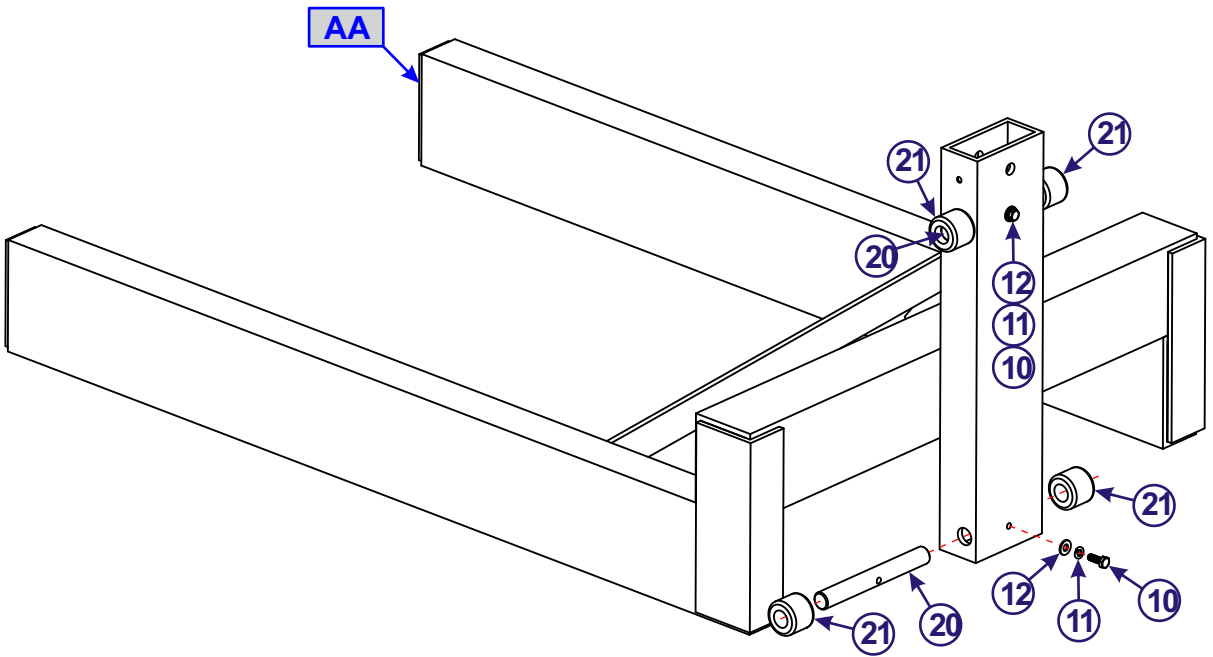

Apply a small amount of anti-seize
inside of rollers prior to placing on
axle

- QTY 2: 1/4 x 1.25" bolt ("10")
- QTY 2: 1/4 flat washer ("12")
- QTY 2: 1/4 lock washer ("11")
- QTY 2: axle ("20")
- QTY 4: roller ("21")

FOR THE MANUAL DRIVE SYSTEM: GO TO PG 13

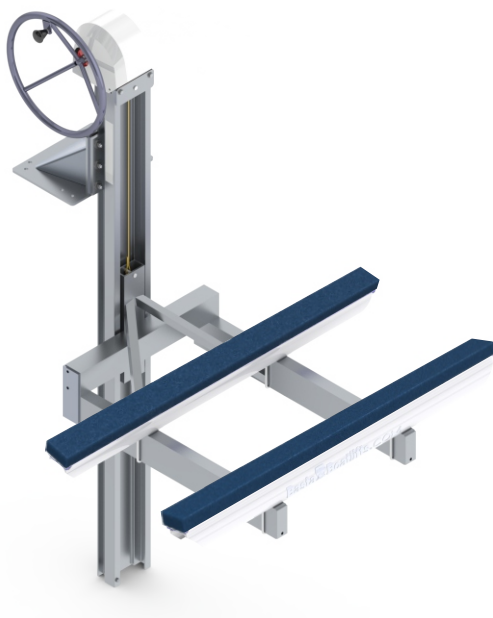

FOR THE 12V ELEC. DRIVE SYSTEM: GO TO PG 14

ASSEMBLY INSTRUCTIONS

NOTE: use a small amount of anti-seize on bolt threads

Cable Installation (Manual)

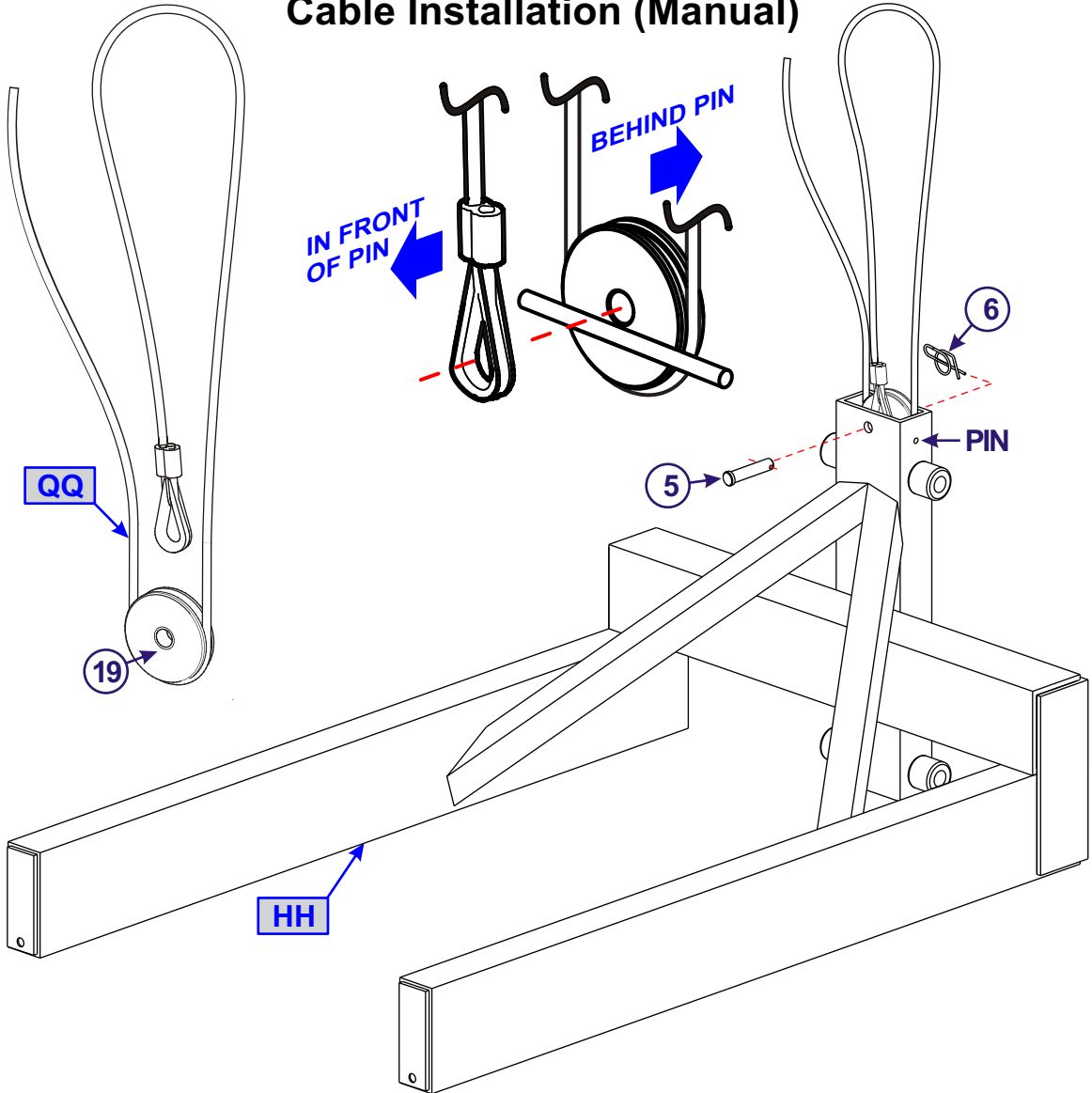

QTY 1: 1/2 x 2-1/2 clevis pin ("5")

QTY 1: ring type cotter pin ("6")

QTY 1: sheave ("19")

QTY 1: lift cable ("QQ")

ASSEMBLY INSTRUCTIONS

NOTE: use a small amount of anti-seize on bolt threads

Upper Tower Assembly (Manual)

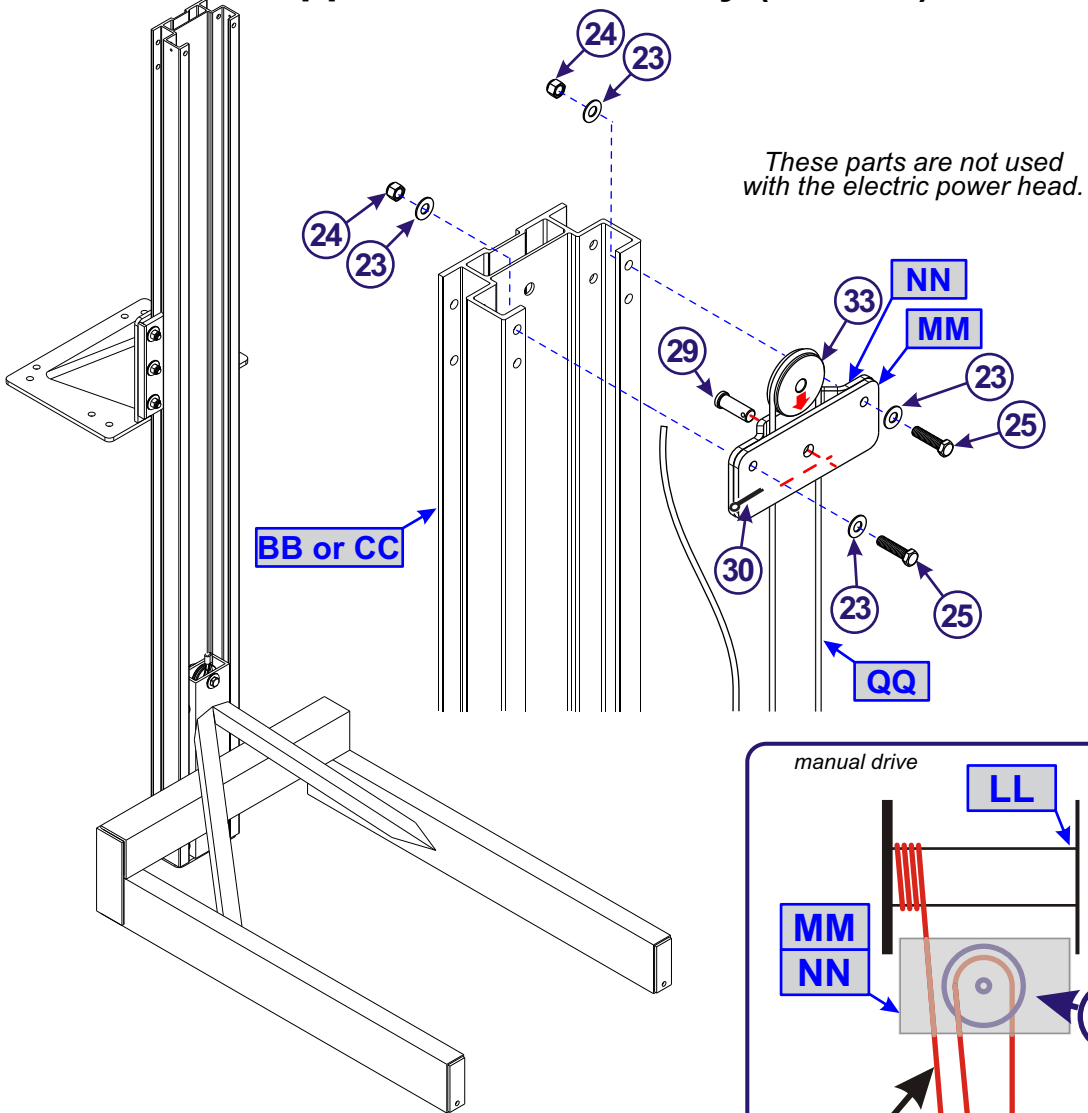

- QTY 2: 3/8 nylock nut ("24")
- QTY 4: 3/8 flat washer ("23")
- QTY 1: 1/2 x 1-1/2 clevis pin ("29")
- QTY 1: cotter pin ("30")
- QTY 1: sheave ("33")
- QTY 2: 3/8 x 1.5" bolt ("25")

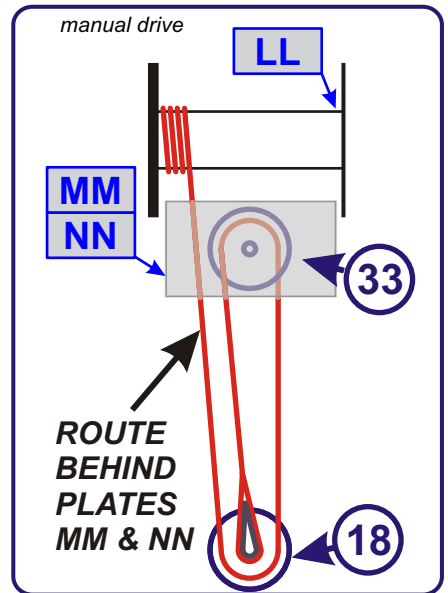

ASSEMBLY INSTRUCTIONS

NOTE: use a small amount of anti-seize on bolt threads

Winch Bracket Installation

Winch Bracket Assembly

- QTY 3: 3/8 x 1.25" bolts ("34")
- QTY 3: 3/8 nylock nuts ("24")
- QTY 6: 3/8 flat washers ("23")

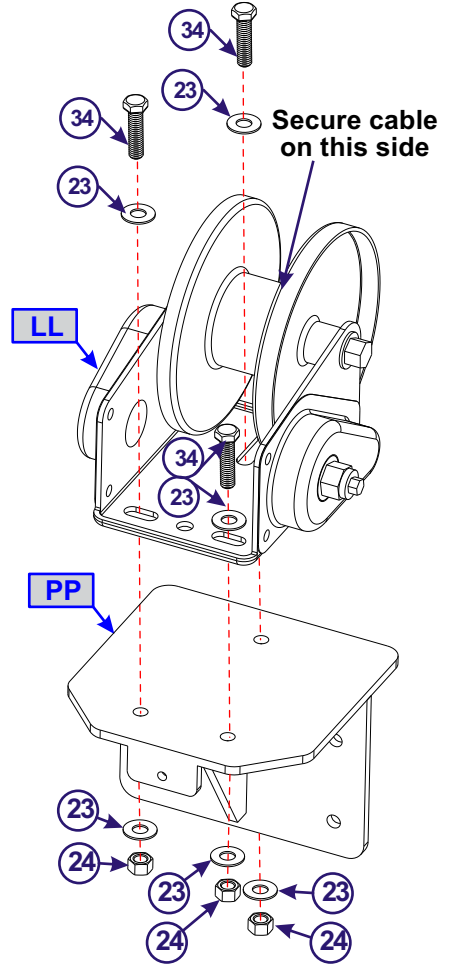

ASSEMBLY INSTRUCTIONS

NOTE: use a small amount of anti-seize on bolt threads

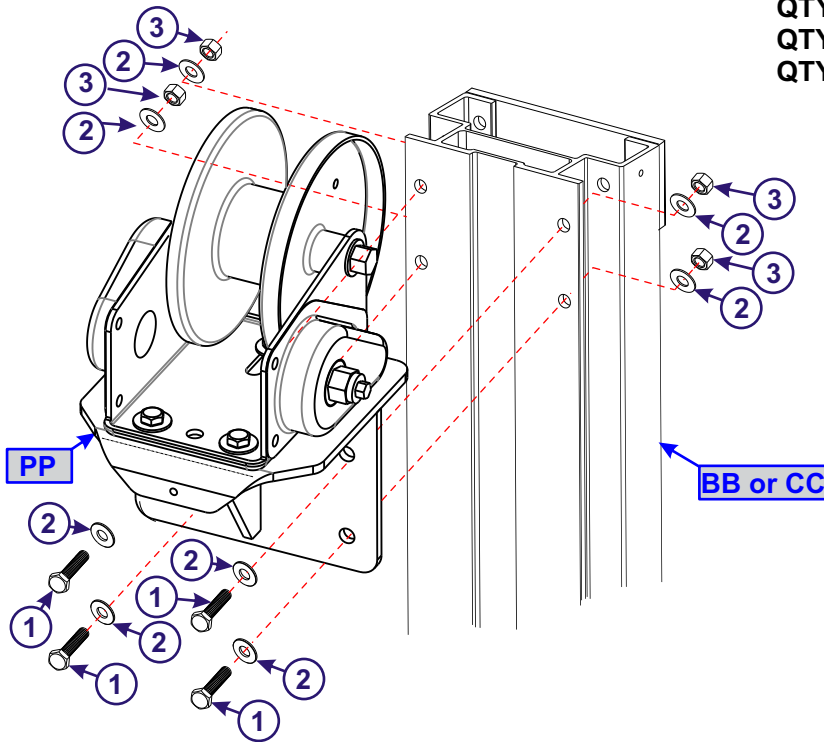

QTY 4: 3/8 x 1.25" bolts ("1")

QTY 4: 3/8 nylock nuts ("3")

QTY 8: 3/8 flat washers ("2")

SECURE CABLE:

With lift in fully lowered position, wrap excess cable around winch drum in counter-clockwise direction and secure as shown.

(Electric hoist wraps in clockwise direction.)

Carriage bolt is inserted into square hole.

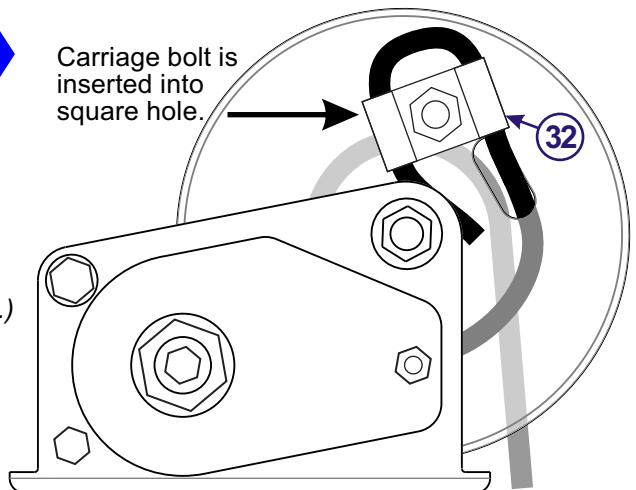

ASSEMBLY INSTRUCTIONS

NOTE: use a small amount of anti-seize on bolt threads

Final Tower Assembly

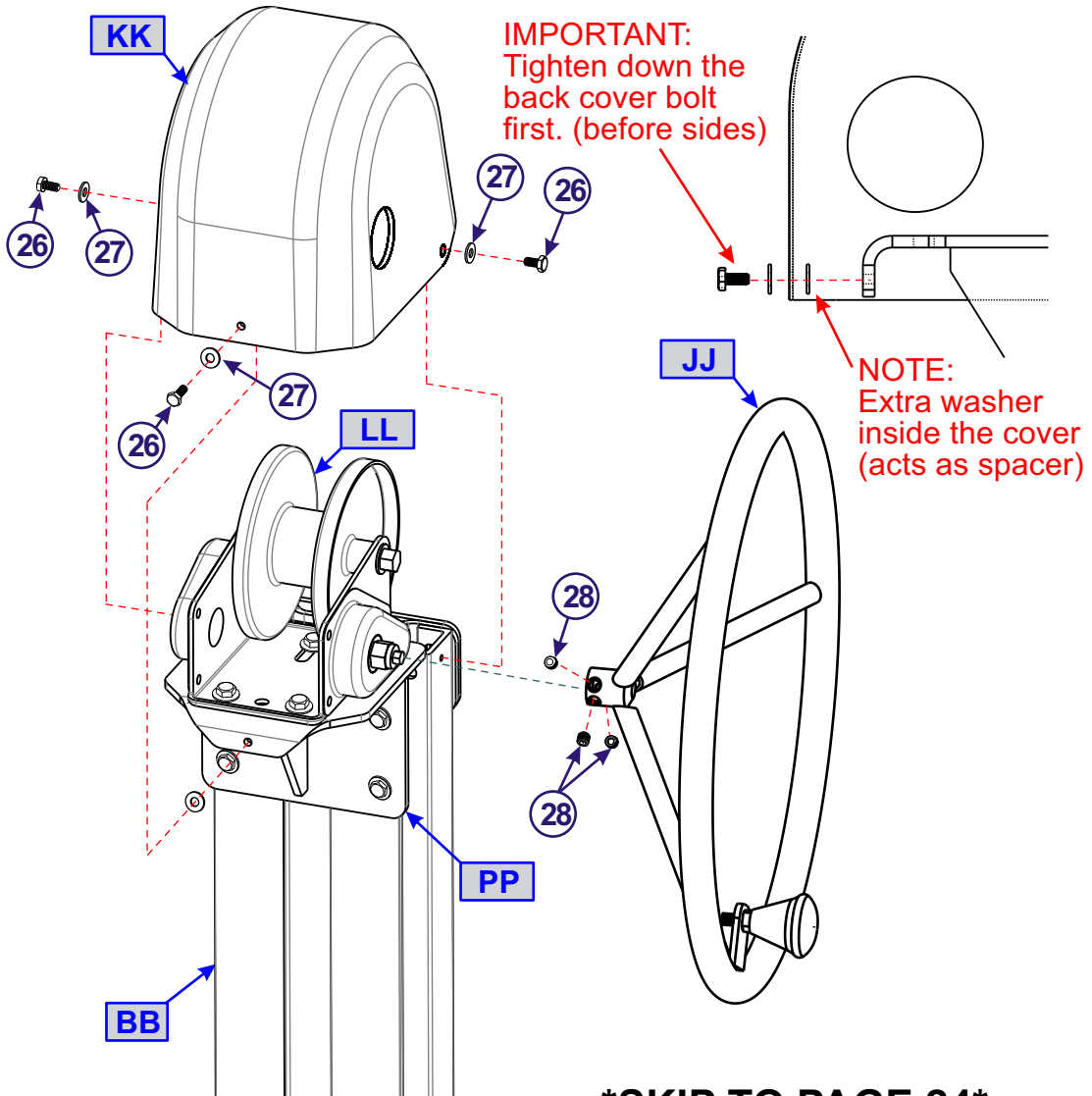

SKIP TO PAGE 24

- QTY 3:** 1/4 x 0.50" bolt ("26")
- QTY 4:** 1/4 flat washer ("27")
- QTY 3:** 3/8-24 x 3/8 cut point set screw ("28")

ASSEMBLY INSTRUCTIONS

Battery Installation

Slide in the battery and attach the battery cables - red to positive & black to negative.

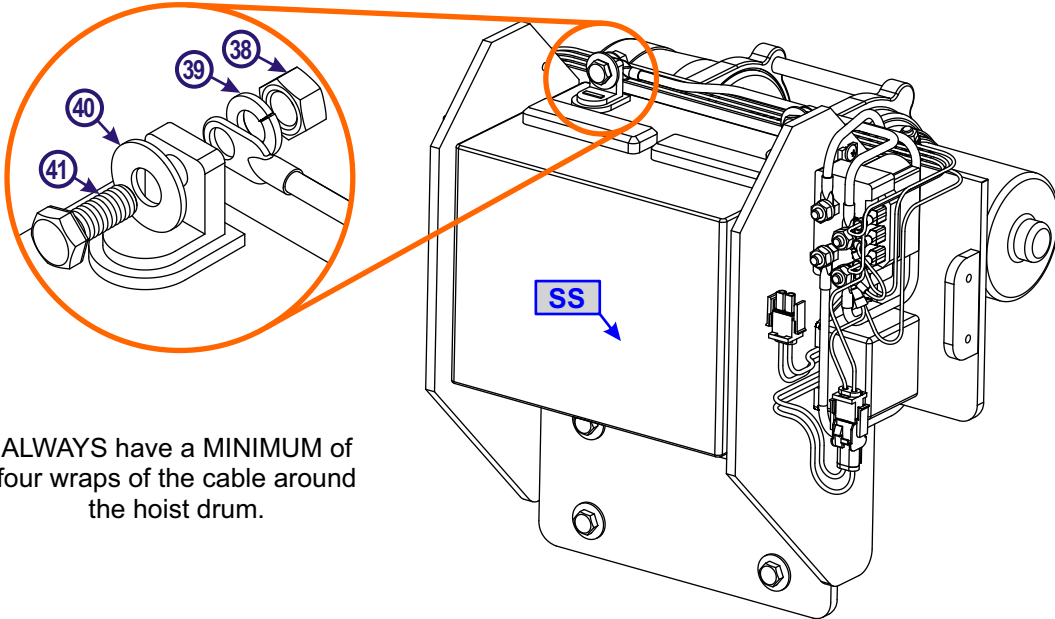

ALWAYS have a MINIMUM of four wraps of the cable around the hoist drum.

Cable routing is different for the manual hoist

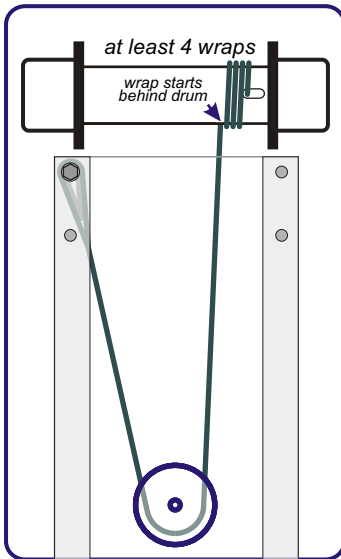

- QTY 2: 1/4 x 0.75" bolts ("41")
- QTY 2: 1/4 flat washers ("40")
- QTY 2: 1/4 lock washers ("39")
- QTY 2: 1/4 - 20 nuts ("38")

Temporarily plug the 6 pin connectors from the cover assembly and the power head assembly together and use the buttons on the remote to unspool enough cable from the hoist drum to string it.

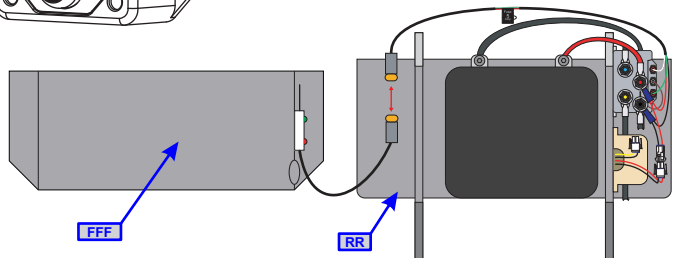
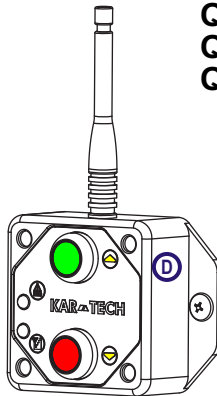

ASSEMBLY INSTRUCTIONS

12V ELECTRIC DRIVE

Power Head Installation

NOTE: use a small amount of anti-seize on bolt threads

Install the power head on the tower with 4 bolts ("1"). Each bolt has a washer ("2") under its head and under the locknut ("17").

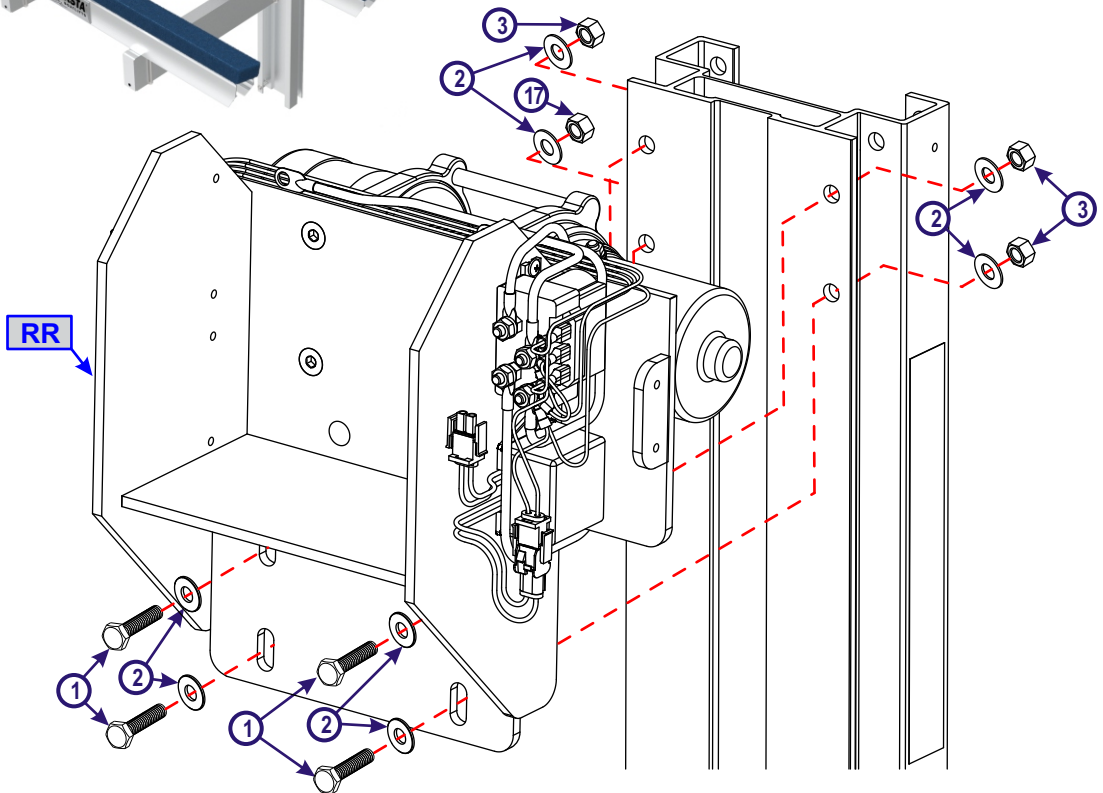

QTY 4: 3/8 x 1.25" bolts ("1")

QTY 4: 3/8 nylock nuts ("3")

QTY 8: 3/8 flat washers ("2")

ASSEMBLY INSTRUCTIONS

Cable Installation (12V)

NOTE: use a small amount of anti-seize on bolt threads

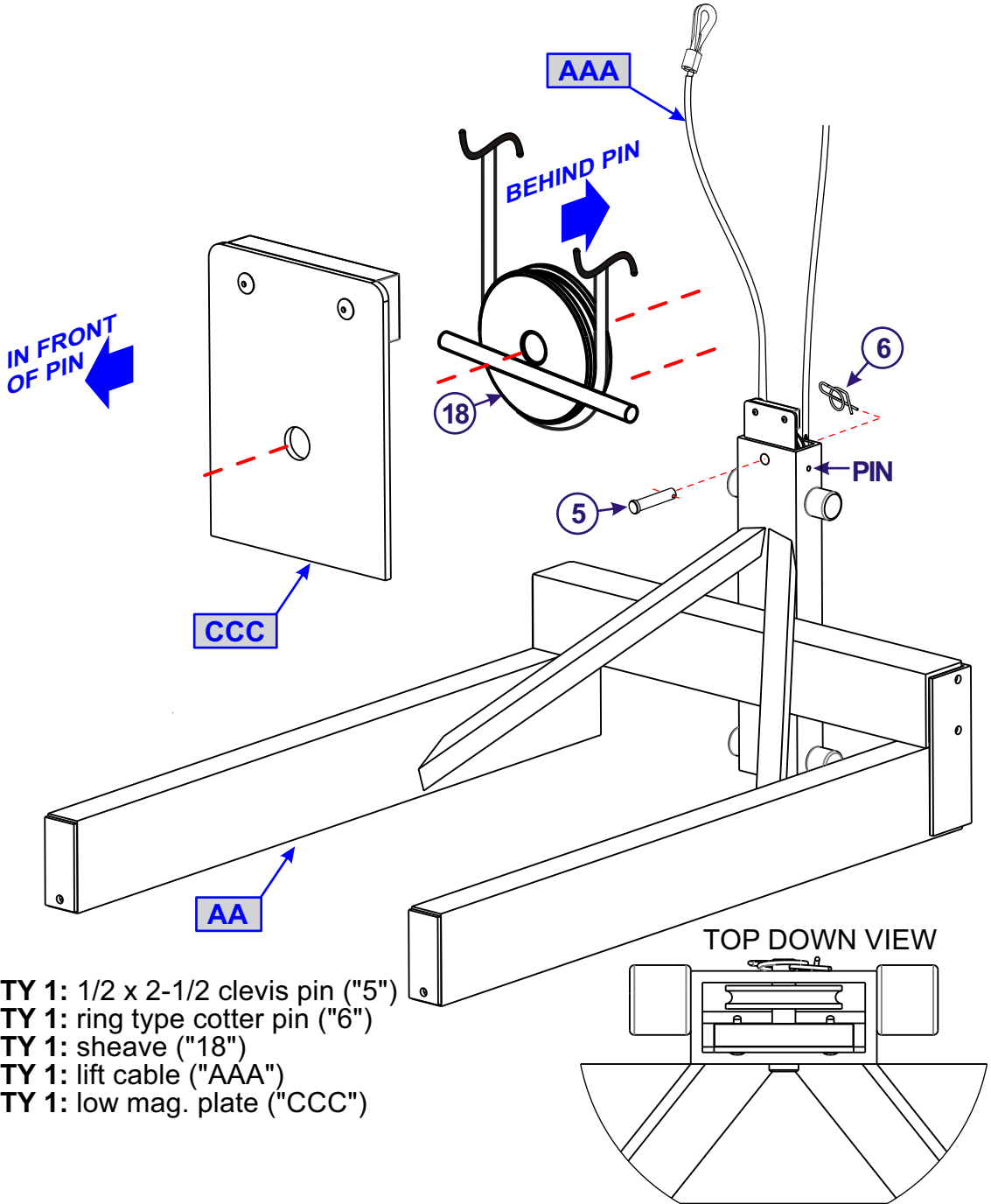

- QTY 1: 1/2 x 2-1/2 clevis pin ("5")
- QTY 1: ring type cotter pin ("6")
- QTY 1: sheave ("18")
- QTY 1: lift cable ("AAA")
- QTY 1: low mag. plate ("CCC")

ASSEMBLY INSTRUCTIONS

Upper Tower Assembly (12V)

NOTE: use a small amount of anti-seize on bolt threads

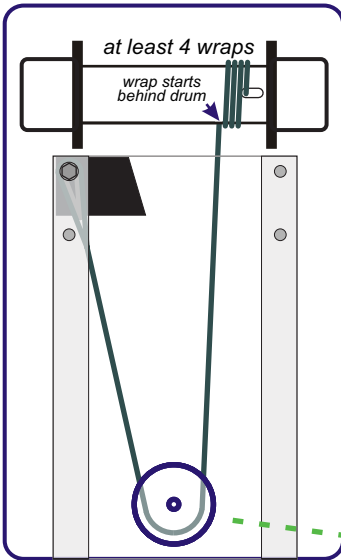
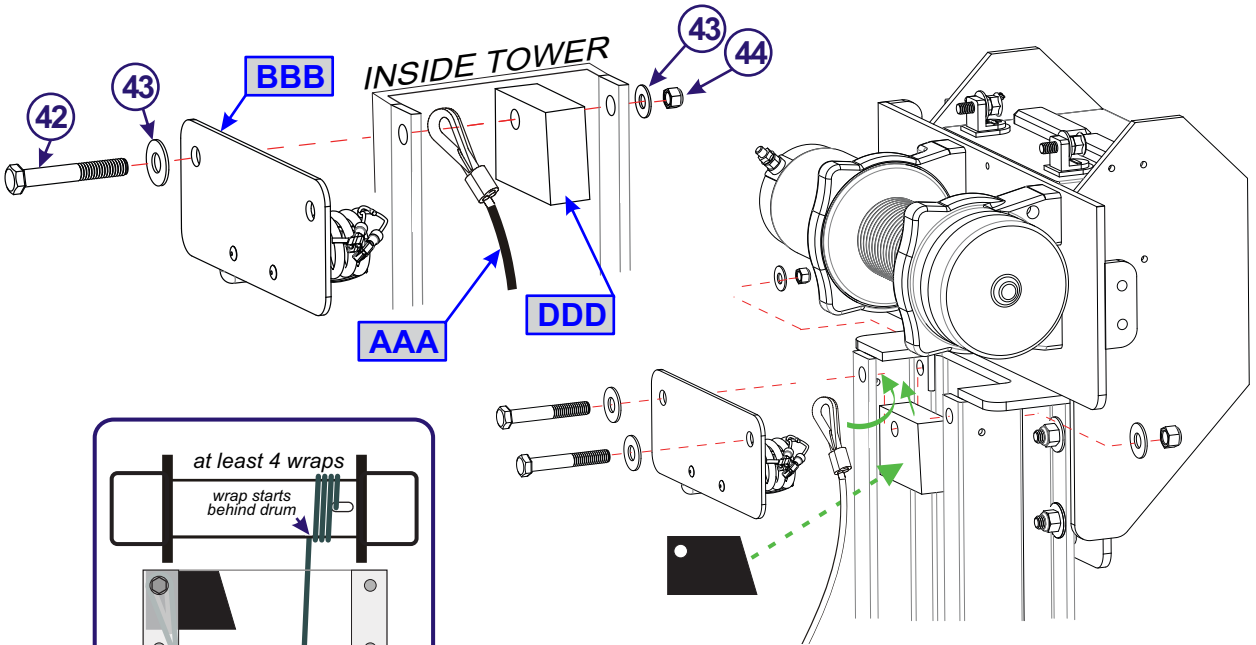

- QTY 2: 3/8 nylock nut ("44")
- QTY 4: 3/8 flat washer ("43")
- QTY 2: 3/8 x 2.75" bolt ("42")
- QTY 1: tensioner block ("DDD")
- QTY 1: up mag. plate ("BBB")

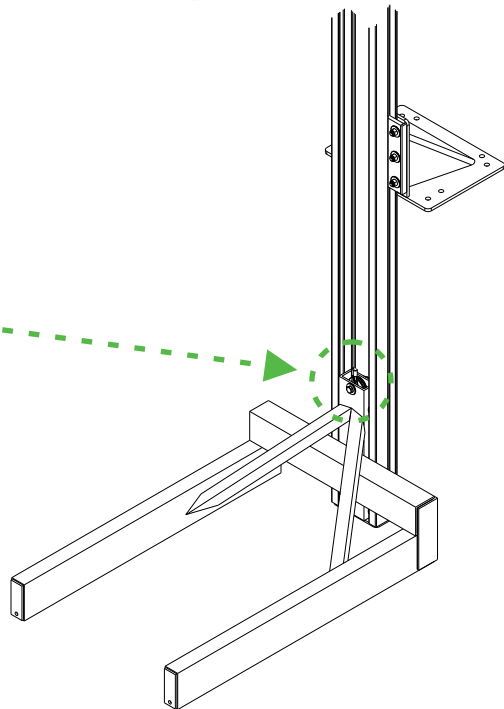

ASSEMBLY INSTRUCTIONS

Power Head Cover Installation

NOTE: use a small amount of anti-seize on bolt threads

Connect the cables from the solar panel and the remote control unit located in the power head cover ("PP") to the Power Head Assembly ("RR"). Lower the cover on to the power head and secure it with four screws ("34").

QTY 4: 1/4" X 1.25" screws ("34")

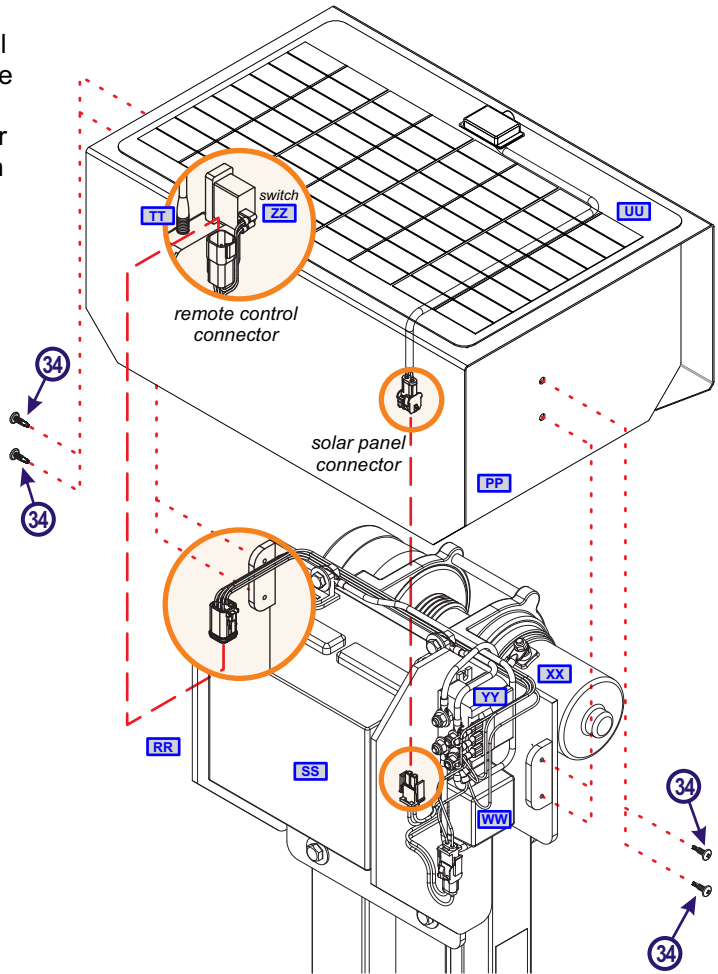

NOTE: Disconnect the solar panel plug from the solar panel controller plug when battery is not installed.

ASSEMBLY INSTRUCTIONS

Limit Switch Hook Up

Route the limit switch cord over the hoist plate so that the coils sit behind the hoist motor.

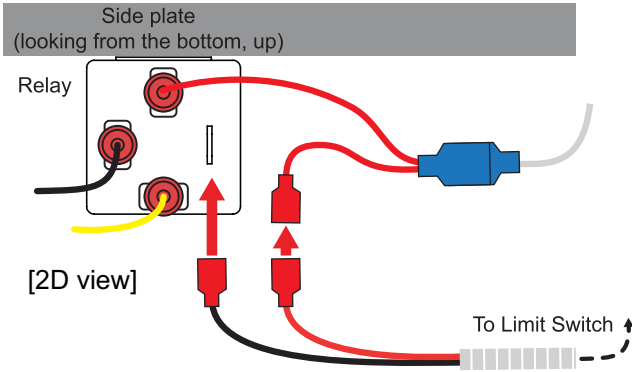
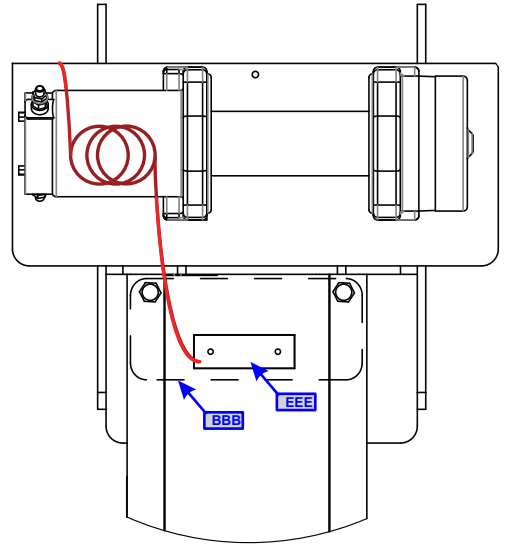

Connect the 2 wires coming out of the limit switch cord:

Red wire to the short red wire coming off the blue connector

Black wire to the only open terminal on the relay

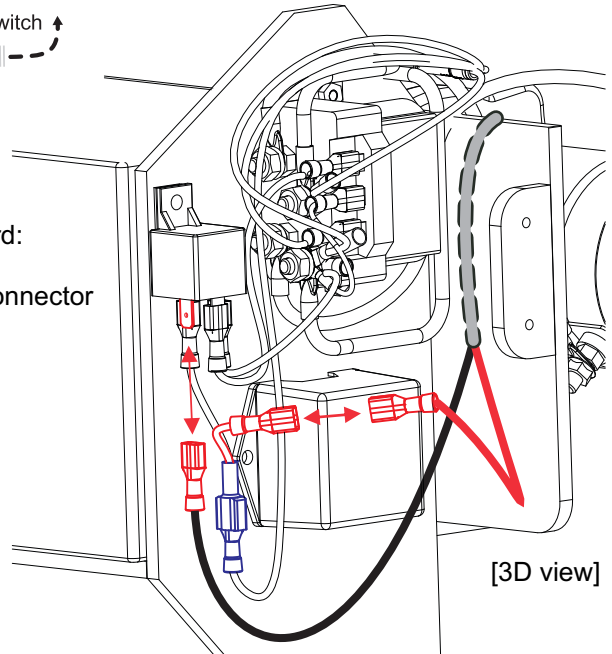

[3D view]

Use these diagrams to help place the lift

1.4k60

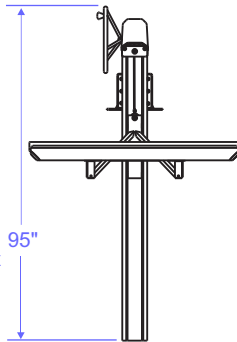
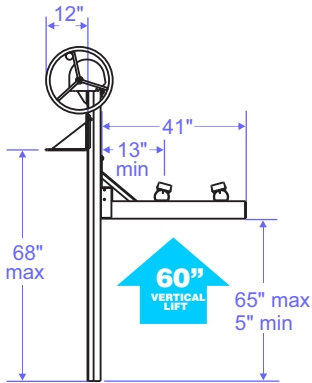
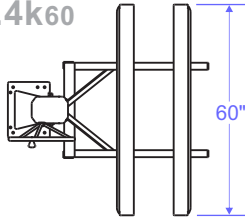

1.4k84

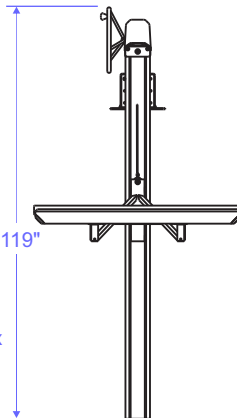
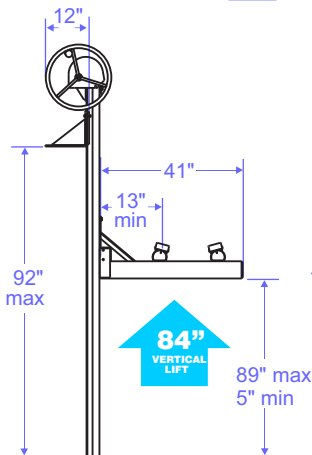
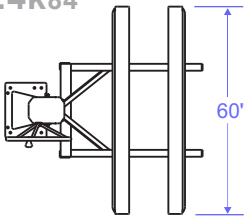

Remote Control

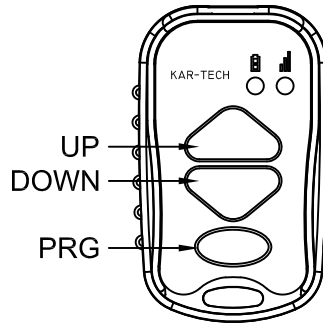

TO REPLACE THE INTERNAL CR2032 DISPOSABLE BATTERY, REMOVE 4 ALLEN SCREWS USING A 3/16" ALLEN WRENCH. LIFT BACK COVER USING GROOVE. DO NOT OVER TIGHTEN THE SCREWS WHEN RE-ASSEMBLING BACK COVER.

Transmitter Fob Reprogramming

If a replacement transmitter is needed, the receiver must be reprogrammed to respond to it.

Do the following:

1. Make sure the lift power switch is OFF and the transmitter fob has no LEDs illuminated.
2. Press and hold the UP and PRG buttons on the transmitter fob for 5 seconds until both LEDs start blinking, then release the buttons.
3. Immediately turn the lift power switch ON.
4. In about 5 seconds, the green LED on the transmitter fob should blink rapidly, indicating success. The new transmitter fob should now operate.

A second transmitter fob may be added. Contact Basta Boatlifts or your dealer for more information.

ASSEMBLY INSTRUCTIONS

NOTE: use a small amount of anti-seize on bolt threads

Bunk Rail Assembly

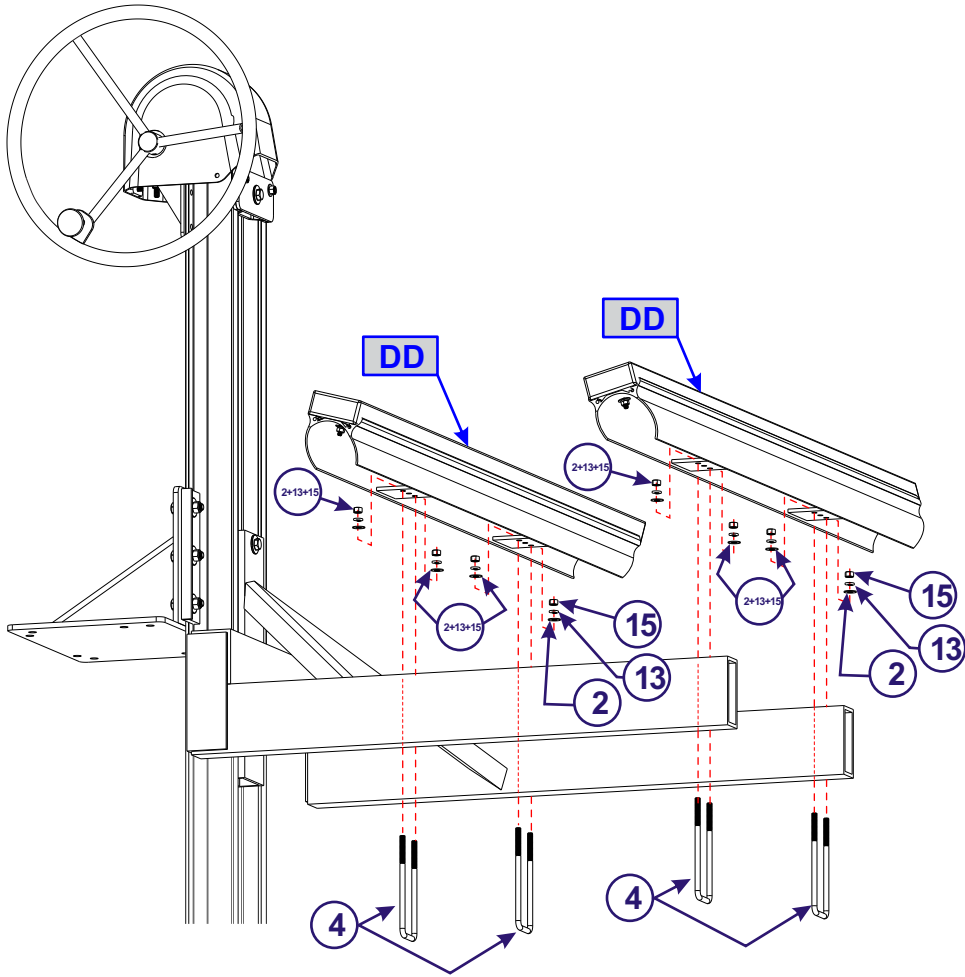

QTY 4: U bolt 3/8 x 2 x 6 ("4")

QTY 8: 3/8 nut ("15")

QTY 8: 3/8 flat washer ("2")

QTY 8: 3/8 lock washer ("13")

FIRST USE AND ADJUSTMENTS

**Maximum lifting capacity is 1400 pounds.
DO NOT OVERLOAD!**

1. DO NOT operate the Lift with a person on either the lift or the watercraft you are lifting.

This lift is NOT designed to lift people.

2. Keep fingers and other foreign objects clear of the winch and cable while it is being operated. Serious injury may result.

3. Do not swim under or around the Lift.

4. Place the boat or water craft over the lift to the following specifications:

- The craft should be centered between the bunks side-to side.
- Move the craft forward to position its center of buoyancy near the bunks' center.
- Disembark and raise the PWC.

Based on Style

5a. (Manual Drive System):

Turn the winch hand wheel in a clockwise direction to raise the lift and counterclockwise to lower. Store the lift with the carriage out of the water. as the lift is raised with a load on the bunks. If the winch is silent when raising the loaded lift, stop immediately. The lift may not keep the load supported if the hand wheel is released.

5b. (Electric Drive System):

Turn on the power using the power switch on the side of the cover. Raise and lower the lift using the up and down buttons on the side of the cover or the remote control fob. Ensure the lift does not raise above the limit switch. Turn off power switch for storage.

6. If the loaded carriage assembly does not lower smoothly, the watercraft may not be properly centered on the lift. *Carefully* lower the lift and make sure the watercraft's weight is centered before lifting it. **Do not attempt to adjust the position of the watercraft while it is raised on the lift.** The bottom of the lift carriage should be stored at least one foot above high water for storage.

7. All fasteners should be checked and tightened regularly to prevent damage to your craft or to the lift.

8. The lift and cable should be inspected for excessive wear or corrosion before use. The connection between the lift and dock is critical and must be carefully monitored.

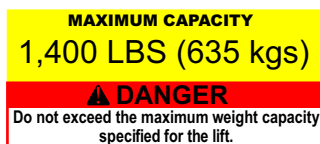



Thank you for investing in one of the finest PWC lifts in the world. We pride ourselves in knowing our product will safely and reliably be the conduit to your fun on the water. Welcome to the Basta Boatlifts family and Boat Happy!

Basta Inc. dba Basta Boatlifts ("Company") warrants its Products (purchased after November 1st, 2021) for non-commercial use for a period of,

- 16 years against manufacturing defects in steel and aluminum lift frame welds.
- 3 years against defects in materials and workmanship including hydraulic components, charging system, remote controls, dock box, bunks, canopies, and accessories.
- 1 year battery warranty when maintained in accordance with battery manufacturer's guidance for batteries supplied by the Company,

to the original Purchaser ("Purchaser"), beginning from date of purchase of the Product from Company. If the Product is purchased from an authorized Company Reseller, the warranty term begins upon the date the new Product is sold to the end Purchaser ("Warranty Start Date").

Annual inspection of the Product bolts, pins, hydraulics, pump, electronics, and welds, by a Company employee or Company authorized agent, shall be conducted. Failure to undertake such maintenance shall constitute "abuse" under Exclusions below.

Company has the right to modify Products at any time without incurring any obligation to make the same or similar modifications on Products previously manufactured or purchased.

Terms And Conditions:

Purchaser must register Product for a valid Warranty. Warranty registration may be found and submitted at:

<https://bastaboatlifts.com/support>.

Notice requirements and remedies:

If the Purchaser discovers a defect, the purchaser shall immediately notify the Company in writing by submission of a Warranty Claim form. Warranty Claim forms may be found and submitted at <https://bastaboatlifts.com/support>. Upon receipt of a complete Warranty Claim form and after confirmation by Company that the Product is defective, the Company, or its authorized Company dealer or agent, will, at the Company's sole discretion:

- 1- repair the Product or,
- 2-replace the defective part with a new or reconditioned part, or
- 3-refund the purchase price of the Product.

Confirmation of the defect shall require that reasonable proof of the defect be

provided by Purchaser to Company or Company authorized agent, and may include that the Product or part be returned to Company for inspection at the Purchaser's initial expense. If the Purchaser chooses to order a replacement part prior to the final determination of the warranty claim, Purchaser will be responsible for the cost of the replacement part and its shipping. If the part is determined to be a valid warranty claim, the customer will be credited the amount of the replacement part and its shipping. Replacement parts for Products outside the United States will be shipped in the next authorized Dealer shipment unless Purchaser agrees to pay for door to door freight of warranted Product. Warranty replacement shall not extend the original warranty of the defective Products. Labor for warranty work to be provided by the Company's Authorized dealer for a period of 3 years from Warranty Start Date, provided there is an active Authorized Dealer within 50 miles of the location of the Product. Labor will not be provided for direct purchases from Company or when an active Authorized Dealer is not located within 50 miles of the location of the Product.

Warranty requests received after expiration of warranty term will not be covered under this warranty regardless of when the defect occurred or was discovered.

Exclusions:

Product changes caused by age or environment (such as marine growth, heat, corrosion or electrolysis) shall not constitute a defect. In addition, this warranty does not cover or apply to the following: damages caused by or due to without limitation: accidents, collision, fire, flood, wind, ice, or any other natural disaster or acts of God, abuse, misuse, overloading, improper watercraft loading, use when out of level, faulty assembly or installation. Lift components' fluid levels and condition, including battery electrolyte (water and acid), hydraulic fluid and strainer cleaning are maintenance items and are not covered by this warranty. Sacrificial anodes (zincs), cosmetic concerns and custom coatings are not covered by this warranty.

Warranty is void if the Product has been modified in any way or if any Company serial number has been removed or defaced. Product purchased from Company, but used on non-Company Products are excluded from this warranty.

Limitations:

To the maximum extent permitted by law except as expressly stated herein, there are no warranties, expressed or implied, by operation of law or otherwise, of the Product furnished under this Agreement. Seller disclaims any implied warranty of merchantability or fitness for a particular purpose. The sole remedy for liability of any kind shall be limited to the remedies provided in this warranty and shall in no event include any incidental, indirect, special or consequential damages or loss of use, revenue or profit. Should the company nevertheless be found liable for any damages, the total liability of the company shall be limited to the purchase price of the Product.

Warranty Registration

WARRANTY MUST BE REGISTERED WITHIN 30 DAYS OF INSTALLATION

PRODUCT INFORMATION

Model #: _____

Serial #: _____

Purchased From: _____

Date of Purchase: _____

Contact Name: _____

Phone #: _____

Notes: _____

IMPORTANT!

TO REGISTER, SCAN HERE OR VISIT
WWW.BASTABOATLIFTS.COM/SUPPORT

